

ARYAN SCHOOL OF ENGINEERING & ECHNOLOGY

BARAKUDA, PANCHAGAON, BHUBANESWAR, KHORDHA-752050

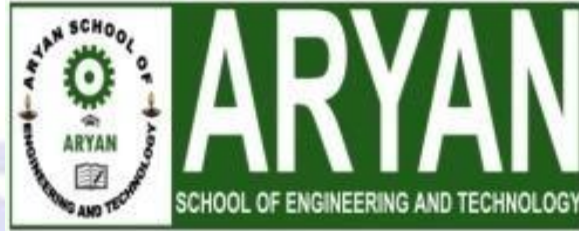

LECTURE NOTE

SUBJECT NAME- HYDRAULIC AND IRRIGATION ENGINEERING

BRANCH-CIVIL ENGG.

SEMESTER-4TH SEM

ACADEMIC SESSION-2022-23

PREPARED BY- DIBYAJYOTI NAYAK

HYDROSTATICS

Hydrostatic is that branch of science which relating to fluids at rest or to the pressures they exert or transmit **Hydrostatic Pressure**.

Fluid:-

Fluid is a substance that continuously deforms (flows) under an applied shear stress. Fluids are a subset of the phase of matter and include liquids, gases, plasmas and, to some extent, plastic solids. Fluids can be defined as substances which have zero shear modulus or in simpler terms a fluid is a substance which cannot resist any shear force applied to it.

- ❖ Fluid is a substance which is capable of flowing
- ❖ Conform the shape of the containing vessel
- ❖ Deform continuously under application of small shear force

1.1 PROPERTIES OF FLUID:-

Density:-

The density of a fluid, is generally designated by the Greek symbol ρ (*rho*), is defined as the mass of the fluid over a unit volume of the fluid at standard temperature and pressure. It is expressed in the SI system as kg/m³.

$$\rho = \lim \frac{\Delta m}{\Delta V} = \frac{dm}{dV}$$

If the fluid is assumed to be uniformly dense the formula may be simplified as:

$$\rho = \frac{m}{V}$$

Example: - setting of fine particles at the bottom of the container.

Specific Weight:-

The specific weight of a fluid is designated by the Greek symbol γ (*gamma*), and is generally defined as the weight per unit volume of the fluid at standard temperature and pressure. In SI systems the units is N/m³.

$$\lambda = \rho * g$$

g = local acceleration of gravity and ρ = density

Note: It is customary to use:

$$g = 32.174 \text{ ft/s}^2 = 9.81 \text{ m/s}^2$$

$$\rho = 1000 \text{ kg/m}^3$$

Relative Density (Specific Gravity):-

The relative density of any fluid is defined as the ratio of the density of that fluid to the density of the standard fluid. For liquids we take water as a standard fluid with density $\rho=1000 \text{ kg/m}^3$. For gases we take air or O_2 as a standard fluid with density, $\rho=1.293 \text{ kg/m}^3$.

Specific volume:-

Specific volume is defined as the volume per unit mass. It is just reciprocal of mass density. It is expressed in m^3/kg .

Viscosity:-

Viscosity (represented by μ , Greek letter mu) is a material property, unique to fluids, that measures the fluid's resistance to flow. Though a property of the fluid, its effect is understood only when the fluid is in motion. When different elements move with different velocities, each element tries to drag its neighboring elements along with it. Thus, shear stress occurs between fluid elements of different velocities.

Viscosity is the property of liquid which destroyed the relative motion between the layers of fluid.

- ❖ It is the internal friction which causes resistance to flow.
- ❖ Viscosity is the property which control the rate of flow of liquid

Viscosity is due to two factors-

- a) Cohesion between the liquid molecules.
- b) Transfer of momentum between the molecules.

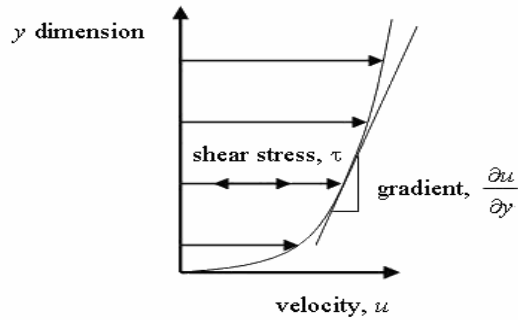

Fig. 1.1

The relationship between the shear stress and the velocity field was that the shear stresses are directly proportional to the velocity gradient. The constant of proportionality is called the coefficient of dynamic viscosity.

$$\tau = \mu \frac{\partial u}{\partial y}$$

UNIT OF VISCOSITY

- ❖ In mks system unit of viscosity is kgf-sec/m²
- ❖ In cgs system unit of viscosity is dyne-sec/cm²
- ❖ In S.I system unit of viscosity is Newton-sec/m²

Kinematic viscosity:-

Another coefficient, known as the kinematic viscosity (ν , Greek nu) is defined as the ratio of dynamic viscosity and density.

I.et, $\nu = \mu/\rho = \text{viscosity/density}$

In mks & S.I system unit of kinematic viscosity is meter²/sec

In cgs system unit of kinematic viscosity is stoke.

SURFACE TENSION:-

Surface tension is defined as the tensile force acting on the surface of a liquid in contact with a gas or on the surface between two immiscible liquids such that the contact surface behaves like a membrane under tension. The magnitude of this force per unit length of the free surface will have the same value as the surface energy per unit area. It is denoted by Greek letter sigma(σ). In MKS units, it is expressed as kgf/m while in SI unit is N/m.

It is also defined as force per unit length, or of energy per unit area. The two are equivalent—but when referring to energy per unit of area, people use the term surface energy—which is a more general term in the sense that it applies also to solids and not just liquids.

Capillarity:-

Capillarity is defined as a phenomenon of rise or fall of a liquid surface in a small tube relative to the adjacent general level of liquid when the tube is held vertically in the liquid. The rise of liquid surface is known as capillary rise while the fall of the liquid surface is known as capillary depression. It is expressed in terms of cm or mm of liquid. Its value depends upon the specific weight of the liquid, diameter of the tube and surface tension of the liquid.

1.2 Pressure and its measurement:-

INTENSITY OF PRESSURE:-

Intensity of pressure is defined as normal force exerted by fluid at any point per unit area. It is also called specific pressure or hydrostatic pressure

$$P = df/da$$

- ❖ If intensity of pressure is uniform over an area “A” then pressure force exerted by fluid equal to

$$\text{Mathematically } F = PA$$

- ❖ If intensity of pressure is not uniform or vary point to point then pressure force exerted by fluid equal to integration of $P \cdot A$

$$\text{Mathematically } F = \int PA$$

- ❖ Unit of pressure

- $1\text{N/m}^2 = 1 \text{ Pascal}$
- $1\text{KN/m}^2 = 1 \text{ kilo Pascal}$
- $\text{Kilo Pascal} = 1\text{kpa} = 10^3 \text{ Pascal}$
- $1 \text{ bar} = 10^5 \text{ Pascal} = 10^5 \text{ N/m}^2$

Pascal's law:-

It states that the pressure or intensity of pressure at a point in a static fluid is equal in all direction.

Atmospheric Pressure:-

The atmospheric air exerts a normal pressure upon all surface with which it is in contact and it is called atmospheric pressure. It is also called parametric pressure.

Atmospheric pressure at the sea level is called standard atmospheric pressure.

$$\begin{aligned} \text{S.A.P} &= 101.3 \text{ KN/m}^2 = 101.3 \text{ kpa} = 10.3\text{m of H}_2\text{O} \\ &= 760 \text{ mm of Hg} \\ &= 10.3 \text{ (milli bar)} \end{aligned}$$

Gauge pressure:-

It is the pressure which measure with help of pressure measuring device in which atmospheric pressure taken as datum.

The atmospheric pressure on scale is marked as zero.

Absolute pressure:-

Any pressure measure above absolute zero pressure is called absolute pressure.

Vacuum pressure:-

Vacuum pressure is defined as the pressure below the atmospheric pressure.

RELATIONSHIP BETWEEN ABSOLUTE PRESSURE, GAUGE PRESSURE, VACUUM PRESSURE:-

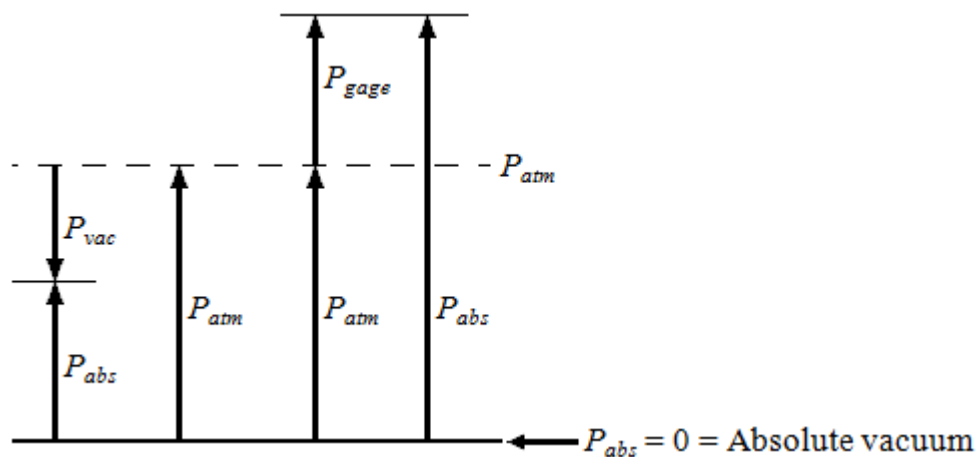

Fig. 1.2

❖ Equations

$P_{\text{gage}} = P_{\text{abs}} - P_{\text{atm}}$	gauge pressure
$P_{\text{vac}} = P_{\text{atm}} - P_{\text{abs}}$	vacuum pressure
$P_{\text{abs}} = P_{\text{atm}} + P_{\text{gage}}$	absolute pressure

❖ Nomenclature

P_{abs}	absolute pressure
P_{gage}	gage pressure
P_{vac}	vacuum pressure
P_{atm}	atmospheric pressure

Pressure Head:-

pressure head is the internal energy of a fluid due to the pressure exerted on its container. It may also be called **static pressure head** or simply **static head** (but not **static head pressure**). It is mathematically expressed as:

$$\psi = \frac{P}{\gamma} = \frac{P}{\rho g}$$

where

ψ is pressure head (Length, typically in units of m);

P is fluid pressure (force per unit area, often as Pa units); and

γ is the specific weight (force per unit volume, typically N/m³ units)

ρ is the density of the fluid (mass per unit volume, typically kg/m³)

g is acceleration due to gravity (rate of change of velocity, given in m/s²)

If intensity of pressure express in terms of height of liquid column, which causes pressure is also called pressure head.

Mathematically, $h = P/w$

Pressure Gauges :-

The pressure of a fluid is measured by the following devices:-

1. manometers
2. mechanical gauges

Manometers:-Manometers are defined as the devices used for measuring the pressure at a point in a fluid by balancing the column of fluid by the same or another column of the fluid. They are classified as:

- a) Simple manometers
- b) Differential manometer

Mechanical gauges:-mechanical gauges are defined as the devices used for measuring the pressure by balancing the fluid column by the spring or dead weight. The commonly used mechanical gauges are:-

- a) Diaphragm pressure gauge
- b) Bourdon tube pressure gauge
- c) Dead weight pressure gauge
- d) Bellows pressure gauge

1.3 PRESSURE EXERTED ON IMMERSED SURFACE:-

Hydrostatic forces on surfaces:-

Hydrostatic means the study of pressure exerted by a liquid at rest. The direction of such pressure is always perpendicular to the surface to which it acts.

Forces on Submerged Surfaces in Static Fluids

These are the following features of statics fluids:-

- Hydrostatic vertical pressure distribution
- Pressures at any equal depths in a continuous fluid are equal
- Pressure at a point acts equally in all directions (Pascal's law).
- Forces from a fluid on a boundary acts at right angles to that boundary.

Fluid pressure on a surface:-

Pressure is defined as force per unit area. If a pressure p acts on a small area δA then the force exerted on that area will be

$$F = p\delta A$$

TOTAL PRESSURE:-

Total pressure is defined as the force exerted by a static fluid on a surface when the fluid comes in contact with the surface.

Mathematically **total pressure**,

$$P = p_1 a_1 + p_2 a_2 + p_3 a_3 \dots \dots \dots$$

Where,

- p_1, p_2, p_3 = Intensities of pressure on different strips of the surface, and
- a_1, a_2, a_3 = Areas of corresponding strips.

The position of an immersed surface may be,

- Horizontal
- Vertical
- Inclined

Total Pressure On A Horizontal Immersed Surface

Consider a plane horizontal surface immersed in a liquid as shown in figure 1.

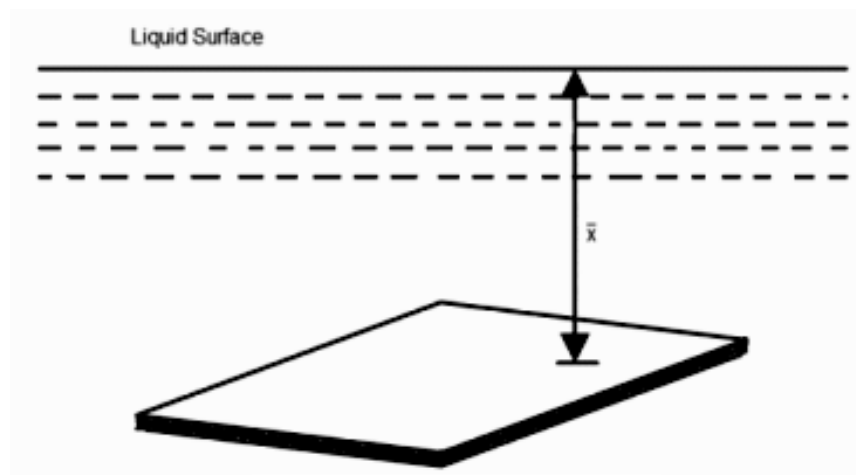

Fig. 1.3

- ω = Specific weight of the liquid
- A = Area of the immersed surface in in^2
- χ = Depth of the horizontal surface from the liquid level in meters

We know that the **Total pressure** on the surface,

P = Weight of the liquid above the immersed surface

= Specific weight of liquid * Volume of liquid

= Specific weight of liquid * Area of surface * Depth of liquid

= $\omega A \chi kN$

Total Pressure On A Vertically Immersed Surface

Consider a plane vertical surface immersed in a liquid shown in figure 2.

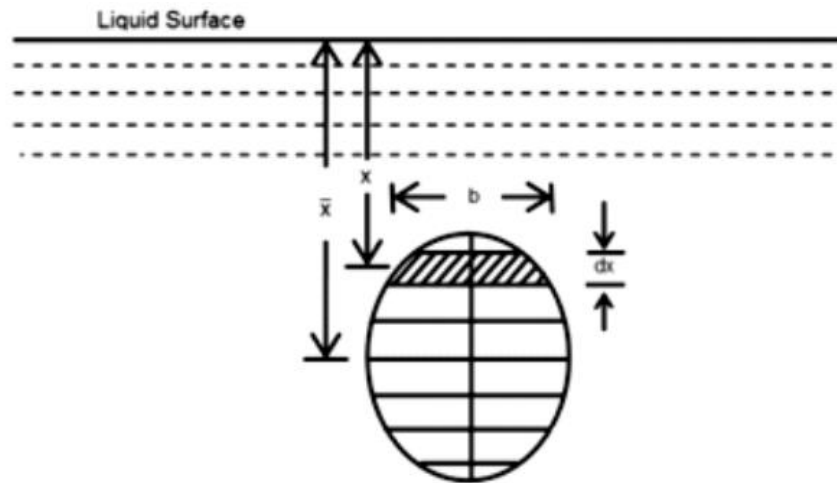

Fig. 1.4

Let the whole immersed surface is divided into a number of small parallel stripes as shown in figure.

Here,

- ω = Specific weight of the liquid
- A = Total area of the immersed surface
- χ = Depth of the center of gravity of the immersed surface from the liquid surface

Now, consider a strip of thickness dx , width b and at a depth x from the free surface of the liquid.

The intensity of pressure on the strip = $\omega \chi$

and the area of strip = $b \cdot dx$

∴ Pressure on the strip = Intensity of pressure * Area = $\omega \chi \cdot b \cdot dx$

Now, Total pressure on the surface,

$$P = \int \omega x \cdot b \cdot dx.$$

$$= w \int x.bdx$$

But, $w \int x.bdx = \text{Moment of the surface area about the liquid level} = A\bar{x}$

$$\therefore P = wA\bar{x}$$

1.4 FLOTATION AND BUOYANCY:-

Archimedes Principle:-

Archimedes' principle indicates that the upward buoyant force that is exerted on a body immersed in a fluid, whether fully or partially submerged, is equal to the weight of the fluid that the body displaces. Archimedes' principle is a law of physics fundamental to fluid mechanics. Archimedes of Syracuse formulated this principle, which bears his name.

Buoyancy:-

When a body is immersed in a fluid an upward force is exerted by the fluid on the body. This upward force is equal to weight of the fluid displaced by the body and is called the force of buoyancy or simple buoyancy.

Centre of pressure:-

The center of pressure is the point where the total sum of a pressure field acts on a body, causing a force to act through that point. The total force vector acting at the center of pressure is the value of the integrated pressure field. The resultant force and center of pressure location produce equivalent force and moment on the body as the original pressure field. Pressure fields occur in both static and dynamic fluid mechanics. Specification of the center of pressure, the reference point from which the center of pressure is referenced, and the associated force vector allows the moment generated about any point to be computed by a translation from the reference point to the desired new point. It is common for the center of pressure to be located on the body, but in fluid flows it is possible for the pressure field to exert a moment on the body of such magnitude that the center of pressure is located outside the body.

Center of buoyancy:-

It is defined as the point through which the force of buoyancy is supposed to act. As the force of buoyancy is a vertical force and is equal to the weight of the fluid displaced by the body, the center of buoyancy will be the center of gravity of the fluid displaced.

METACENTER:-

The metacentric height (GM) is a measurement of the initial static stability of a floating body. It is calculated as the distance between the centre of gravity of a ship and its metacentre. A larger metacentric height implies greater initial stability against overturning. Metacentric height also has implication on the natural period of rolling of a hull, with very large metacentric heights

being associated with shorter periods of roll which are uncomfortable for passengers. Hence, a sufficiently high but not excessively high metacentric height is considered ideal for passenger ships.

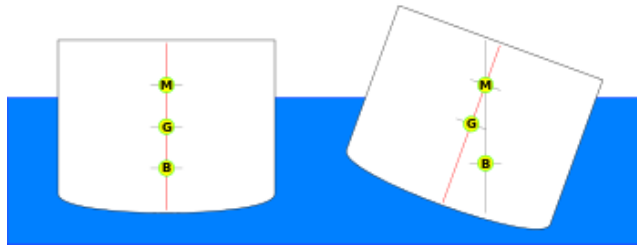

Fig. 1.5

The metacentre can be calculated using the formulae:

$$KM=KB+BM$$

$$BM = \frac{I}{V}$$

Metacentric height:-

The distance between the meta-center of a floating body and a center of gravity of the body is called metacentric height.

$$MG = BM - BG$$

$$MG = I/V - BG$$

Stability of a submerged body:-

Stable condition:-

- ❖ For stable condition $w = f_b$ and the point “B” above the CG of the body.

Unstable equilibrium:-

- ❖ For unstable equilibrium $w = f_b$ and the point B is below the CG of the body.

Neutral equilibrium:-

- ❖ If the force of buoyancy is act as CG of the body.

Stability of a floating body:-

- ❖ For stable condition $w = f_b$ and the meta centre “m” is about the CG of the body.
- ❖ For unstable equilibrium $w = f_b$ and the metacentre “m” is below CG of the body.
- ❖ In neutral equilibrium $w = f_b$ and metacentre “m” is acting at CG of the body.

KINEMATICS OF FLUID FLOW

2.1 Basic equation of fluid flow and their application:-

Energy of a Liquid in Motion:-

The energy, in general, may be defined as the capacity to do work. Though the energy exists in many forms, yet the following are important from the subject point of view:

1. Potential energy,
2. Kinetic energy, and
3. Pressure energy.

Potential Energy of a Liquid Particle in Motion:-

It is energy possessed by a liquid particle by virtue of its position. If a liquid particle is Z m above the horizontal datum (arbitrarily chosen), the potential energy of the particle will be Z metre-kilogram (briefly written as mkg) per kg of the liquid. The potential head of the liquid, at point, will be Z metres of the liquid.

Kinetic Energy of a Liquid Particle in Motion:-

It is the energy, possessed by a liquid particle, by virtue of its motion or velocity. If a liquid particle is flowing with a mean velocity of v metres per second; then the kinetic energy of the particle will be $V^2/2g$ mkg per kg of the liquid. Velocity head of the liquid, at that velocity, will be $V^2/2g$ metres of the liquid.

Pressure Energy of a Liquid Particle in Motion:-

It is the energy, possessed by a liquid particle, by virtue of its existing pressure. If a liquid particle is under a pressure of p kN/m² (i.e., kPa), then the pressure energy of the particle will be $\frac{P}{w}$ mkg per kg of the liquid, where w is the specific weight of the liquid. Pressure head of the liquid

under that pressure will be $\frac{P}{w}$ metres of the liquid.

Total Energy of a Liquid Particle in Motion:-

The total energy of a liquid, in motion, is the sum of its potential energy, kinetic energy and pressure energy. Mathematically total energy,

$$E = Z + V^2/2g + \frac{P}{w} \text{ m of Liquid.}$$

Total Head of a Liquid Particle in Motion:-

The total head of a liquid particle, in motion, is the sum of its potential head, kinetic head and pressure head. Mathematically, total head,

$$H = Z + V^2/2g + \frac{P}{w} \text{ m of liquid.}$$

Example

Water is flowing through a tapered pipe having end diameters of 150 mm and 50 mm respectively. Find the discharge at the larger end and velocity head at the smaller end, if the velocity of water at the larger end is 2 m/s. Solution. Given: $d_1 = 150\text{mm} = 0.15\text{ m}$; $d_2 = 50\text{ mm} = 0.05\text{ m}$ and $V_1 = 2.5\text{ m/s}$. Discharge at the larger end We know that the cross-sectional area of the pipe at the larger end,

$$a_1 = \frac{\pi}{4} \times (0.15)^2 = 17.67 \times 10^{-3} \text{m}^2$$

and discharge at the larger end,

$$Q_1 = a_1 \cdot v_1 = (17.67 \times 10^{-3}) \times 2.5 = 44.2 \times 10^{-3} \text{ m}^3/\text{s} \\ = 44.2 \text{ litres/s} \quad \text{Ans.}$$

Velocity head at the smaller end

We also know that the cross-sectional area of the pipe at the smaller end,

$$A_2 = \frac{\pi}{4} \times (0.05)^2 = 1.964 \times 10^{-3} \text{m}^2$$

Since the discharge through the pipe is continuous, therefore

$$a_1 \cdot v_1 = a_2 \cdot v_2$$

$$\text{or } v_2 = \frac{a_1 \cdot v_1}{a_2} = \frac{[(17.67 \times 10^{-3}) \times 2.5]}{1.964 \times 10^{-3}} = 22.5 \text{ m/s}$$

\therefore Velocity head at the smaller end

$$V_2^2/2g = (22.5)^2/2 \times 9.81 = 25.8 \text{ m} \quad \text{Ans}$$

Bernoulli's Equation:-

It states, "For a perfect incompressible liquid, flowing in a continuous stream, the total energy; of a particle remains the same, while the particle moves from one point to another." This statement is based on the assumption that there are no "losses due to friction in the pipe. Mathematically,

$$Z + V^2/2g + \frac{P}{w} = \text{Constant}$$

where

Z = Potential energy,

$V^2/2g$ = Kinetic energy, and

$\frac{P}{w}$ = Pressure energy.

Proof

Consider a perfect incompressible liquid, flowing through a non-uniform pipe as shown in Fig-

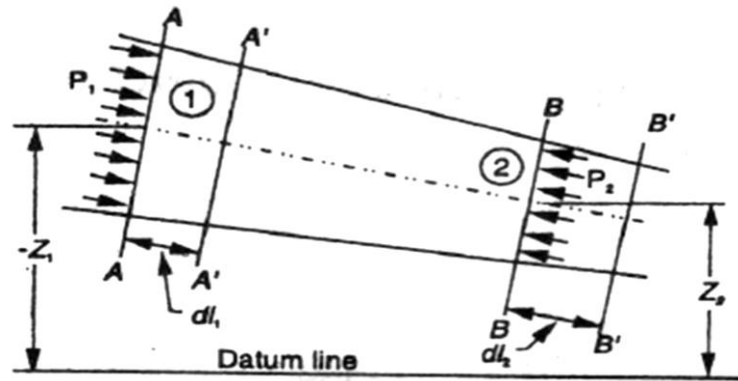

Fig. 2.1

Let us consider two sections AA and BB of the pipe. Now let us assume that the pipe is running full and there is a continuity of flow between the two sections.

Let

Z_1 = Height of AA above the datum,

P_1 = Pressure at AA,

V_1 = Velocity of liquid at AA,

A_1 = Cross-sectional area of the pipe at AA, and

Z_2, P_2, V_2, A_2 = Corresponding values at BB.

Let the liquid between the two sections AA and BB move to A' A' and B' B' through very small lengths dl_1 and dl_2 as shown in Fig. This movement of the liquid between AA and BB is equivalent to the movement of the liquid between AA and A' A' to BB and B' B', the remaining liquid between A' A' and BB being unaffected.

Let W be the weight of the liquid between AA and A' A'. Since the flow is continuous, therefore

$$W = w a_1 dl_1 = w a_2 dl_2$$

$$\text{or} \quad a_1 \times dl_1 = \frac{W}{w} \quad \dots(i)$$

$$\text{Similarly} \quad a_2 dl_2 = \frac{W}{w}$$

$$\therefore a_1 \cdot dl_1 = a_2 \cdot dl_2 \quad \dots(ii)$$

We know that work done by pressure at AA, in moving the liquid to A' A'

$$= \text{Force} \times \text{Distance} = P_1 \cdot a_1 \cdot dl_1$$

Similarly, work done by pressure at BB, in moving the liquid to B' B'

$$= -P_2 a_2 dl_2$$

...(Minus sign is taken as the direction of P_2 is opposite to that of P_1)

\therefore Total work done by the pressure

$$= P_1 a_1 dl_1 - P_2 a_2 dl_2$$

$$= P_1 a_1 dl_1 - P_2 a_1 dl_1$$

$$\dots(a_1 dl_1 = a_2 dl_2)$$

$$= a_1 \cdot dl_1 (P_1 - P_2) = \frac{W}{w} (P_1 - P_2) \dots(a_1 \cdot dl_1 = \frac{W}{w})$$

Loss of potential energy = $W (Z_1 - Z_2)$

and again in kinetic energy = $W[(V_2^2/2g) - (V_1^2/2g)] = \frac{W}{2g} (v_2^2 - v_1^2)$

We know that loss of potential energy + Work done by pressure = Gain in kinetic energy

$$\therefore W (Z_1 - Z_2) + \frac{W}{w} (P_1 - P_2) = \frac{W}{2g} (v_2^2 - v_1^2)$$

$$(Z_1 - Z_2) + (p_1/w) - (p_2/w) = v_2^2/2g - v_1^2/2g$$

$$\text{Or } Z_1 + v_1^2/2g + (p_1/w) = Z_2 + v_2^2/2g + (p_2/w)$$

which proves the Bernoulli's equation.

Euler's Equation For Motion

The "Euler's equation for steady flow of an ideal fluid along a streamline" is based on the Newton's Second Law of Motion. The integration of the equation gives Bernoulli's equation in the form of energy per unit weight of the flowing fluid. It is based on the following assumptions:

1. The fluid is non-viscous (i.e., the frictional losses are zero).
2. The fluid is homogeneous and incompressible (i.e., mass density of the fluid is constant).
3. The flow is continuous, steady and along the streamline.
4. The velocity of flow is uniform over the section.
5. No energy or force (except gravity and pressure forces) is involved in the flow.

Consider a steady flow of an ideal fluid along a streamline. Now consider a small element AB of the flowing fluid as shown in Fig.

Let

dA = Cross-sectional area of the fluid element,

ds = Length of the fluid element,

dW = Weight of the fluid element,

p = Pressure on the element at A,

$p + dp$ = Pressure on the element at B, and

v = Velocity of the fluid element.

We know that the external forces tending to accelerate the fluid element in the direction of the streamline

$$= p \cdot dA - (p + dp) dA$$

$$= -dp \cdot dA$$

We also know that the weight of the fluid element,

$$dW = \rho g \cdot dA \cdot ds$$

From the geometry of the figure, we find that the component of the weight of the fluid element, in the direction of flow

$$= - \rho g \cdot dA \cdot ds \cos \theta$$

$$= - \rho g \cdot dA \cdot ds \left(\frac{dz}{ds} \right)$$

$$= - \rho g \cdot dA \cdot dz$$

$$\therefore \text{mass of the fluid element} = \rho \cdot dA \cdot ds$$

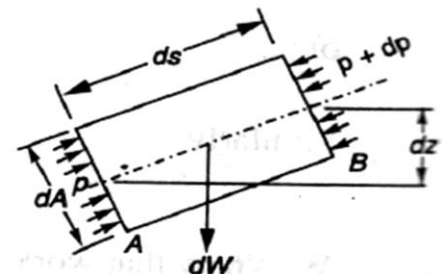

Fig. 2.2

$$\dots \cos \theta = \frac{dz}{ds}$$

, We see that the acceleration of the fluid element

$$\frac{dv}{dt} = \frac{dv}{ds} \times \frac{ds}{dt} = v \cdot \frac{dv}{ds}$$

Now, as per Newton's Second Law of Motion, we know that

Force = Mass x Acceleration

$$(- dp \cdot dA) - (\rho g \cdot dA \cdot dz) = \rho \cdot dA \cdot ds \times \frac{dv}{ds}$$

$$\frac{dp}{\rho} + g \cdot dz = v \cdot dv$$

...(dividing both side by -

ρdA)

$$\text{Or } \frac{dp}{\rho} + g \cdot dz + v \cdot dv = 0$$

This is the required Euler's equation for motion and is in the form of a differential equation.

Integrating the above equation,

$$\frac{1}{\rho} \int dp + \int g \cdot dz + \int v \cdot dv = \text{constant}$$

$$\frac{p}{\rho} + g_z + v^2/2 = \text{constant}$$

$$P + wZ + Wv^2/2g = \text{constant}$$

$$\frac{p}{w} + Z + v^2/2g = \text{constant (Dividing by } w)$$

$$\text{or in other words, } \frac{p_1}{w} + Z_1 + (v_1^2/2g) = \frac{p_2}{w} + Z_2 + (v_2^2/2g)$$

which proves the Bernoulli's equation.

Limitations of Bernoulli's Equation:-

The Bernoulli's theorem or Bernoulli's equation has been derived on certain assumptions, which are rarely possible. Thus the Bernoulli's theorem has the following limitations:

1. The Bernoulli's equation has been derived under the assumption that the velocity of every liquid particle, across any cross-section of a pipe, is uniform. But, in actual practice, it is not so. The velocity of liquid particle in the centre of a pipe is maximum and gradually decreases towards the walls of the pipe due to the pipe friction. Thus, while using the Bernoulli's equation, only the mean velocity of the liquid should be taken into account.
2. The Bernoulli's equation has been derived under the assumption that no external force, except the gravity force, is acting on the liquid. But, in actual practice, it is not so. There are always some external forces (such as pipe friction etc.) acting on the liquid, which effect the flow of the liquid. Thus, while using the Bernoulli's equation, all such external forces should be neglected. But, if some energy is supplied to, or, extracted from the flow, the same should also be taken into account.
3. The Bernoulli's equation has been derived, under the assumption that there is. no loss of energy of the liquid particle while flowing. But, in actual practice, -it is rarely so. In a turbulent flow, some kinetic energy is converted into heat energy. And in a viscous flow, some energy is lost due to shear forces. Thus, while using Bernoulli's equation, all such losses should be neglected.

4. If the liquid is flowing in a curved path, the energy due to centrifugal force should also be taken into account.

Example

The diameter of a pipe changes from 200 mm at a section 5 metres-above datum = to 50 mm at a section 3 metres above datum. The pressure of water at first section is 500 kPa. If the velocity of flow at the first section is 1 m/s, determine the intensity of pressure at the second section.

Solution. Given: $d_1 = 200 \text{ mm} = 0.2 \text{ m}$; $Z_1 = 5 \text{ m}$; $d_2 = 50 \text{ mm} = 0.05 \text{ m}$; $Z_2 = 3 \text{ m}$; $p = 500 \text{ kPa} = 500 \text{ kN/m}^2$ and $V_1 = 1 \text{ m/s}$.

Let

$V_2 =$ Velocity of flow at section 2, and

$P_2 =$ Pressure at section 2. We know that area of the pipe at section 1 $a_1 = \frac{\pi}{4} \times 0.2^2 = 31.42 \times 10^{-3} \text{ m}^2$

and area of pipe at section 2 $a_2 = \frac{\pi}{4} \times 0.05^2 = 1.964 \times 10^{-3} \text{ m}^2$

Since the discharge through the pipe is continuous, therefore $a_1 \cdot V_1 = a_2 \cdot V_2$

$$V_2 = \frac{a_1 \cdot v_1}{a_2} = [(31.42 \times 10^{-3}) \times 1] / 1.964 \times 10^{-3} = 16 \text{ m/s}$$

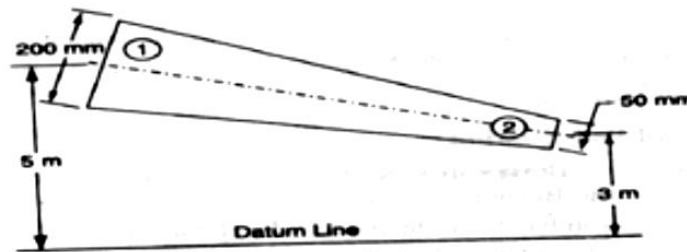

Fig. 2.3

Applying Bernoulli's equation for both the ends of the pipe,

$$Z_1 + v_1^2/2g + (p_1/w) = Z_2 + v_2^2/2g + (p_2/w)$$

$$5 + (1)^2/(2 \times 9.81) + 500/9.81 = 3 + (16)^2/2 \times 9.81 + \frac{p_2}{9.81}$$

$$P_2 = 40 \times 9.81 = 392.4 \text{ kN/m}^2 = 392.4 \text{ kPa} \text{ Ans}$$

practical Applications of Bernoulli's Equation

The Bernoulli's theorem or Bernoulli's equation is the basic equation which has the widest applications in Hydraulics and Applied Hydraulics. Since this equation is applied for the derivation

of many formulae, therefore its clear understanding is very essential. Though the Bernoulli's equation has a number of practical applications, yet in this chapter we shall discuss its applications on the following 'hydraulic devices':

1. Venturi meter.
2. Orifice meter.
3. Pitot tube.

Venturimeter

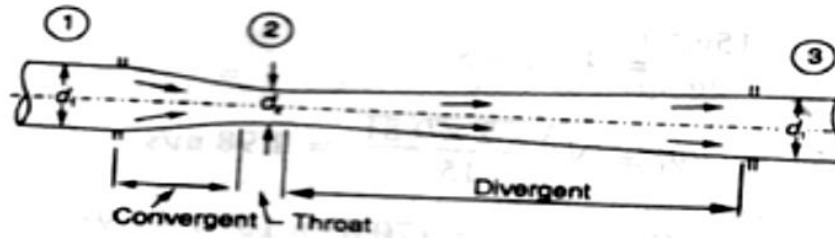

Fig. 2.4

A venturi meter is an apparatus for finding out the discharge of a liquid flowing in a pipe. A- venture meter, in its simplest form, consists of the following three parts:

- (a) Convergent cone.
- (b) Throat.
- (c) Divergent cone.

(a) Convergent cone

It is a short pipe which converges from a diameter d_1 (diameter of the pipe in which the venturi meter is fitted) to a smaller diameter d_2 . The convergent cone is also known as inlet of the venturi meter. The slope of the converging sides is between 1 in 4 or 1 in 5 as shown in Fig.

(b) Throat

It is a small portion of circular pipe in which the diameter d_2 is kept constant as shown in Fig.

(c) Divergent cone

It is a pipe, which diverges from a diameter d_2 to a large diameter d_1 . The divergent cone is also known as outlet of the venturi meter. The length of the divergent cone is about 3 to 4 times than that of the convergent cone as shown in Fig.

A little consideration will show that the liquid, while flowing through the venturi meter, is accelerated between the sections 1 and 2 (i.e., while flowing through the convergent cone). As a result of the acceleration, the velocity of liquid at section 2 (i.e., at the throat) becomes higher than that at section 1. This increase in velocity results in considerably decreasing the pressure at section 2. If the pressure head at the throat falls below the separation head (which is 2.5 metres of water), then there will be a tendency of separation of the liquid flow. In order to avoid the tendency of separation at throat, there is always a fixed ratio of the diameter of throat and the pipe (i.e., d_2/d_1). This ratio varies from $1/4$ to $3/4$, but the most suitable value is $1/3$ to $1/2$.

The liquid, while flowing through the venturi meter, is decelerated (i.e., retarded) between the sections 2 and 3 (i.e., while flowing through the divergent cone). As a result of this retardation, the velocity of liquid decreases which, consequently, increases the pressure. If the pressure is rapidly recovered, then there is every possibility for the stream of liquid to break away from the walls of the metre due to boundary layer effects. In order to avoid the tendency

of breaking away the stream of liquid, the divergent cone is made sufficiently longer. Another reason for making the divergent cone longer is to minimise the frictional losses. Due to these reasons, the divergent cone is 3 to 4 times longer than convergent cone as shown in Fig.

Discharge through a Venturi meter

Consider a venturi meter through which some liquid is flowing as shown in Fig.

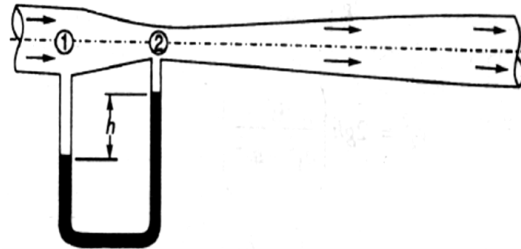

Fig. 2.5

Let

P_1 = Pressure at section 1,

V_1 = Velocity of water at section 1,

Z_1 = Datum head at section 1,

a_1 = Area of the venturi meter at section 1, and

p_2, v_2, z_2, a_2 = Corresponding values at section 2.

Applying Bernoulli's equation at sections 1 and 2. i.e

$$Z_1 + v_1^2/2g + (p_1/w) = Z_2 + v_2^2/2g + (p_2/w) \quad \dots\dots(1)$$

Let us pass our datum line through the axis of the venturi meter as shown in Fig.

Now $Z_1=0$ and $Z_2=0$

$$\therefore v_1^2/2g + (p_1/w) = v_2^2/2g + (p_2/w)$$

$$\text{Or } (p_1/w) - (p_2/w) = v_2^2/2g - v_1^2/2g \quad \dots\dots(2)$$

Since the discharge at sections 1 and 2 is continuous, therefore

$$V_1 = a_2 v_2 / a_1 \quad (a_1 v_1 = a_2 v_2)$$

$$V_1^2 = a_2^2 v_2^2 / a_1^2 \quad \dots\dots(3)$$

Substituting the above value of v_1^2 in equation (2),

$$\begin{aligned} \frac{p_1}{w} - \frac{p_2}{w} &= v_2^2/2g - (a_2^2/a_1^2) \times v_2^2/2g \\ &= v_2^2/2g (1 - a_2^2/a_1^2) = v_2^2/2g [(a_1^2 - a_2^2)/a_1^2] \end{aligned}$$

We know that $\frac{p_1}{w} - \frac{p_2}{w}$ is the difference between the pressure heads at sections 1 and 2 when the pipe is horizontal, this difference represents the venturi head and is denoted by h .

$$\text{Or } h = v_2^2/2g [(a_1^2 - a_2^2)/a_1^2]$$

$$\text{Or } v_2^2 = 2gh[a_1^2/(a_1^2 - a_2^2)]$$

$$\therefore v_2 = \sqrt{2gh} [a_1/\sqrt{a_1^2 - a_2^2}]$$

We know that the discharge through a venturi meter,

$$Q = \text{Coefficient of venturi meter} \times a_2 v_2$$

$$= C \cdot a_2 v_2 = [C a_1 a_2 / \sqrt{a_1^2 - a_2^2}] \times \sqrt{2gh}$$

Example

A venturi meter with a 150 mm diameter at inlet and 100 mm at throat is laid with its axis horizontal and is used for measuring the flow of oil specific gravity 0.9. The oil-mercury differential manometer shows a gauge difference of 200 mm. Assume coefficient of the metre as 0.9 Calculate the discharge in litres per minute.

Solution. Given: $d_1 = 150 \text{ mm} = 0.15 \text{ m}$; $d_2 = 100 \text{ mm} = 0.1 \text{ m}$; Specific gravity of oil = 0.9
 $h = 200 \text{ mm} = 0.2 \text{ m}$ of mercury and $C = 0.98$.

We know that the area at inlet,

$$a_1 = \frac{\pi}{4} \times 0.15^2 = 17.67 \times 10^{-3} \text{ m}^2$$

and the area at throat,

$$a_2 = \frac{\pi}{4} \times 0.1^2 = 7.854 \times 10^{-3} \text{ m}^2$$

We also know that the difference of pressure head,

$$H = 0.2(13.6 - 0.9/0.9) = 2.82 \text{ m of oil}$$

and the discharge through the venturi meter,

$$Q = [C a_1 a_2 / \sqrt{a_1^2 - a_2^2}] \times \sqrt{2gh}$$

$$= 63.9 \times 10^{-3} \text{ m}^3/\text{s} = 63.9 \text{ lit/s} \quad \text{Ans.}$$

Orifice Metre

An orifice metre is used to measure the discharge in a pipe. An orifice metre, in its simplest form, consists of a plate having a sharp edged circular hole known as an orifice. This plate is fixed inside a pipe as shown in Fig. c. A mercury manometer is inserted to know the difference

of pressures between the pipe and the throat (i.e., orifice).

Let

h = Reading of the mercury manometer,

P_1 = Pressure at inlet,

V_1 = Velocity of liquid at inlet,

a_1 = Area of pipe at inlet, and

P_2, v_2, a_2 = Corresponding values at the throat.

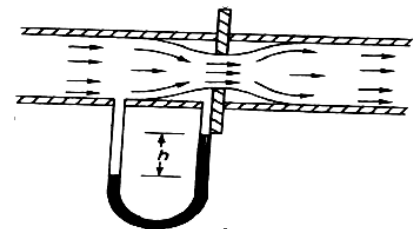

Fig. 2.6

Now applying Bernoulli's equation for inlet of the pipe and the throat,

$$Z_1 + v_1^2/2g + (p_1/w) = Z_2 + v_2^2/2g + (p_2/w) \quad \dots\dots\dots(i)$$

$$(p_1/w) - (p_2/w) = v_2^2/2g - v_1^2/2g$$

$$\text{Or } h = v_2^2/2g - v_1^2/2g = 1/2g(v_2^2 - v_1^2) \quad \dots\dots\dots(ii)$$

Since the discharge is continuous, therefore $a_1 \cdot v_1 = a_2 v_2$

$$v_1 = a_2/a_1 \times v_2 \quad \text{or } v_1^2 = a_2^2/a_1^2 \times v_2^2$$

Substituting the above value of v_1^2 in equation (ii)

$$h = 1/2g(v_2^2 - a_2^2/a_1^2 \times v_2^2) = v_2^2/2g \times (1 - a_2^2/a_1^2) = v_2^2/2g[(a_1^2 - a_2^2)/a_1^2]$$

$$\therefore v_2^2 = 2gh[a_1^2/(a_1^2 - a_2^2)] \quad \text{or } v_2 = \sqrt{2gh} [a_1/\sqrt{a_1^2 - a_2^2}]$$

We know that the discharge,

$$Q = \text{Coefficient of orifice} \times a_2 \cdot v_2$$

$$= [C_a a_2 / \sqrt{a_1^2 - a_2^2}] \times \sqrt{2gh}$$

Example. An orifice metre consisting of 100 mm diameter orifice in a 250 mm diameter pipe has coefficient equal to 0.65. The pipe delivers oil (sp. gr. 0.8). The pressure difference on the two sides of the orifice plate is measured by a mercury oil differential in a manometer. If the differential gauge reads 80 mm of mercury, calculate the rate of flow in litres.

Solution. Given: $d_2 = 100 \text{ mm} = 0.1 \text{ m}$; $d_1 = 250 \text{ mm} = 0.25 \text{ m}$; $C = 0.65$; Specific gravity of oil = 0.8 and $h = 0.08 \text{ m}$ of mercury.

We know that the area of pipe,

$$a_1 = \frac{\pi}{4} \times 0.25^2 = 49.09 \times 10^{-3} \text{ m}^2$$

and area of throat

$$a_2 = \frac{\pi}{4} \times 0.1^2 = 7.854 \times 10^{-3} \text{ m}^2$$

We also know that the pressure difference,

$$h = 0.8[(13.6 - 0.8)/0.8] = 12.8 \text{ m of oil}$$

and rate of flow,

$$Q = [C_a a_2 / \sqrt{a_1^2 - a_2^2}] \times \sqrt{2gh}$$

$$= 82 \times 10^{-3} \text{ m}^3/\text{s} = 82 \text{ lit/s} \quad \text{Ans}$$

Pitot Tube.

A Pitot tube is an instrument to determine the velocity of flow at the required point in a pipe or a stream. In its simplest form, a pitot tube consists of a glass tube bent a through 90° as shown in Fig.

The lower end of the tube faces the direction of the flow as shown in Fig. The liquid rises up in the tube due to the pressure exerted by the flowing liquid. By measuring the rise of liquid in the tube, we can find out the velocity of the liquid flow.

Let h = Height of the liquid in the pitot tube above the surface,

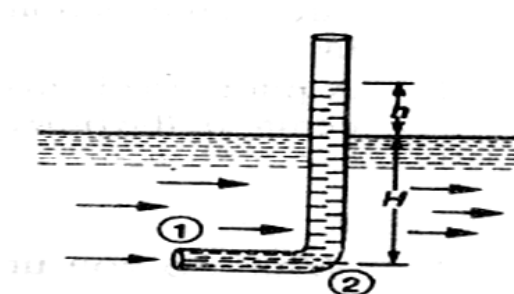

Fig. 2.7

H = Depth of tube in the liquid, and

v = Velocity of the liquid.

Applying Bernoulli's equation for the sections 1 and 2,

$$H + \frac{v^2}{2g} = H + h$$

$$\dots (z_1 = z_2)$$

$$h = \frac{v^2}{2g}$$

$$\therefore v = \sqrt{2gh}$$

Example .

A pitot tube was inserted in a pipe to measure the velocity of water in it. If (water rises the tube is 200 mm, find the velocity of water.

Solution. Given: $h = 200 \text{ mm} = 0.2 \text{ m}$.

We know that the velocity of water in the pipe,

$$v = \sqrt{2gh} = \sqrt{2 \times 9.81 \times 0.2} = 1.98 \text{ m/s Ans.}$$

Rate of Discharge

The quantity of a liquid, flowing per second through a section of a pipe or a channel, is known as the rate of discharge or simply discharge. It is generally denoted by Q . Now consider a liquid flowing through a pipe.

Let, a = Cross-sectional area of the pipe, and

v = Average velocity of the liquid,

$$\therefore \text{Discharge, } Q = \text{Area} \times \text{Average velocity} = a.v$$

Notes: 1. If the area is in m^2 and velocity in m/s , then the discharge,

$$Q = m^2 \times m/s = m^3/s = \text{cumecs}$$

2. Remember that $1m^3 = 1000 \text{ litres}$.

Equation of Continuity of a Liquid Flow

If an incompressible liquid is continuously flowing through a pipe or a channel (whose cross-sectional area may or may not be constant) the quantity of liquid passing per second is the same at all sections. This is known as the equation of continuity of a liquid flow. It is the first and fundamental equation of flow.

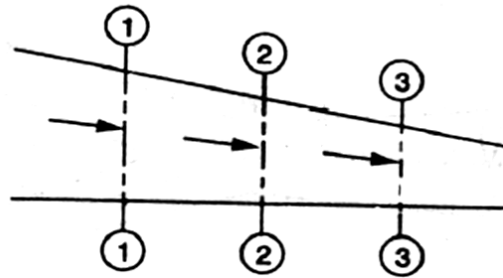

Fig. 2.8

CONTINUITY OF A LIQUID FLOW

Consider a tapering pipe through which some liquid is flowing as shown in Fig

Let, $a_1 =$ Cross-sectional area of the pipe at section 1-1, and

$v_1 =$ Velocity of the liquid at section 1-1,

Similarly, $a_2, v_2 =$ Corresponding values at section 2-2,

and $a_3, v_3 =$ Corresponding values at section 3-3.

We know that the total quantity of liquid passing through section 1-1,

$$Q_1 = a_1.v_1 \dots\dots\dots(i)$$

Similarly, total quantity of liquid passing through section 2-2,

$$Q_2 = a_2.v_2 \dots\dots\dots(ii)$$

and total quantity of the liquid passing through section 3-3,

$$Q_3 = a_3.v_3 \dots\dots\dots(iii)$$

From the law of conservation of matter, we know that the total quantity of liquid passing through the sections 1-1, 2-2 and 3-3 is the same. Therefore

$$Q_1 = Q_2 = Q_3 = \dots\dots \text{ or } a_1.v_1 = a_2.v_2 = a_3.v_3 \dots\dots \text{ and so on.}$$

Example : Water is flowing through a pipe of 100 mm diameter with an average velocity 10 m/s. Determine the rate of discharge of the water in litres/s. Also determine the velocity of water

At the other end of the pipe, if the diameter of the pipe is gradually changed to 200 mm.

Solution. Given: $d_1 = 100 \text{ mm} = 0.1 \text{ m}$; $V_1 = 10 \text{ m/s}$ and $d_2 = 200 \text{ mm} = 0.2 \text{ m}$.

Rate of discharge

We know that the cross-sectional area of the pipe at point 1,

$$a_1 = \left(\frac{\pi}{4}\right) \times (0.1)^2 = 7.854 \times 10^{-3} \text{ m}^2$$

and rate of discharge, $Q = a_1 \cdot v_1 = (7.854 \times 10^{-3}) \times 10 = 78.54 \times 10^{-3} \text{ m}^3/\text{s}$
 $= 78.54 \text{ litres/s}$ **Ans.**

Velocity of water at the other end of the pipe

We also know that cross-sectional area of the pipe at point 2,

$$a_2 = \left(\frac{\pi}{4}\right) \times (0.2)^2 = 31.42 \times 10^{-3} \text{ m}^2$$

and velocity of water at point 2, $v_2 = \frac{Q}{a_2} = ((78.54 \times 10^{-3}) / (31.42 \times 10^{-3})) = 2.5 \text{ m/s}$ **Ans.**

2.2 Flow over Notches:-

A notch is a device used for measuring the rate of flow of a liquid through a small channel or a tank. It may be defined as an opening in the side of a tank or a small channel in such a way that the liquid surface in the tank or channel is below the top edge of the opening.

A weir is a concrete or masonry structure, placed in an open channel over which the flow occurs. It is generally in the form of vertical wall, with a sharp edge at the top, running all the way across the open channel. The notch is of small size while the weir is of a bigger size. The notch is generally made of metallic plate while weir is made of concrete or masonry structure.

1. Nappe or Vein. The sheet of water flowing through a notch or over a weir is called Nappe or Vein.
2. Crest or Sill. The bottom edge of a notch or a top of a weir over which the water flows, is known as the sill or crest.

Classification Of Notches And Weirs:-

The notches are classified as :

I. According to the shape of the opening:

- (a) Rectangular notch,
- (b) Triangular notch,
- (c) Trapezoidal notch, and
- (d) Stepped notch.

2. According to the effect of the sides on the nappe:

- (a) Notch with end contraction.
- (b) Notch without end contraction or suppressed notch e,

Weirs are classified according to the shape of the opening the' shape of the crest, the effect of the sides on the nappe and nature of discharge. The following are important classifications.

Discharge Over A Rectangular Notch Or Weir

The expression for discharge over a rectangular notch or weir is the same.

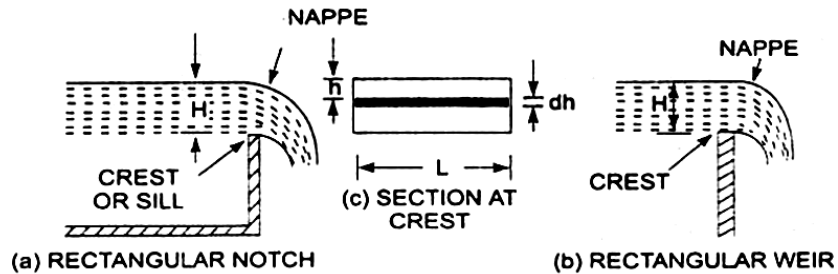

Fig. 2.9

Rectangular notch and 'weir:-

Consider a rectangular notch or weir provided in a channel carrying water as shown in Fig. Let H = Head of water over the crest L = Length of the notch or weir

The total discharge, $Q = \frac{2}{3} \times C_d \times L \times \sqrt{2g[H]}^{3/2}$

Problem - 1

Find the discharge of water flowing over a rectangular notch $0/2$ in length when the constant head over the notch is 300 mm. Take $C_d = 0.60$.

Solution. Given:

Length of the notch, $L = 2.0\text{m}$

Head over notch, $H = 300\text{ mm} = 0.30\text{ m}$

$C_d = 0.60$

Discharge $Q = \frac{2}{3} \times C_d \times L \times \sqrt{2g[H]}^{3/2}$

$$= \frac{2}{3} \times 0.6 \times 2.0 \times \sqrt{2 \times 9.81} \times [0.30]^{3/2} = 1.5\text{ m}^3/\text{s}$$

$$= 3.5435 \times 0.1643 = 0.582\text{ m}^3/\text{s}. \text{ Ans,}$$

Problem 2

Determine the height of a rectangular weir of length 6 m to be built across a Rectangular channel. The maximum depth of water on the upstream side of the weir is 1.8m and discharge is 2000 litres/s. Take $C_d = 0.6$ and neglect end contractions.

Solution. Given:

Length of weir, $L = 6\text{m}$

Depth of water, $H_1 = 1.8\text{m}$

Discharge, $Q = 2000\text{ lit/s} = 2\text{ m}^3/\text{s}$

$$C_d = 0.6$$

Let H is the height of water above the crest of weir and H_2 = height of weir

The discharge over the weir is given by the equation .

$$Q = \frac{2}{3} \times C_d \times L \times \sqrt{2g} [H]^{3/2}$$

$$= \frac{2}{3} \times 0.6 \times 6 \times \sqrt{2} \times 9.81 \times [H]^{3/2}$$

$$= 10.623 H^{3/2}$$

$$= H^{3/2} = \frac{2.0}{10.623}$$

$$H = \left(\frac{2.0}{10.623} \right)^{2/3} = 0.328 \text{ m}$$

Height of weir, $H_2 = H_1 - H$

= Depth of water on upstream side - H

$$= 1.8 - 0.328 = 1.472 \text{ m. Ans.}$$

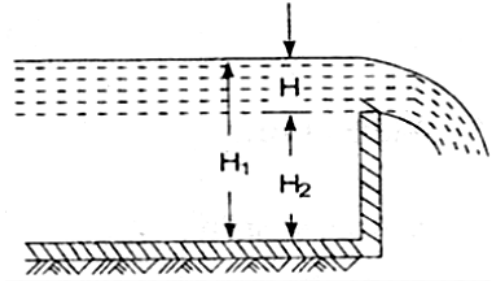

Fig. 2.10

Discharge Over A Triangular Notch Or Weir:-

The expression for the discharge over a triangular notch or weir is the same. It is derived as :

Let H = head of water above the V- notch

θ = angle of notch

$$\text{Total discharge, } Q = \frac{8}{15} \times C_d \times \frac{\tan \theta}{2} \times \sqrt{2g} \times H^{5/2}$$

For a right angle V Notch ,if $C_d = 0.6$

$$\theta = 90^\circ, \tan \frac{\theta}{2} = 1$$

$$\text{Discharge, } Q = \frac{8}{15} \times 0.6 \times 1 \times \sqrt{2 \times 9.81} \times H^{5/2}$$

$$= 1.417 \times H^{5/2}$$

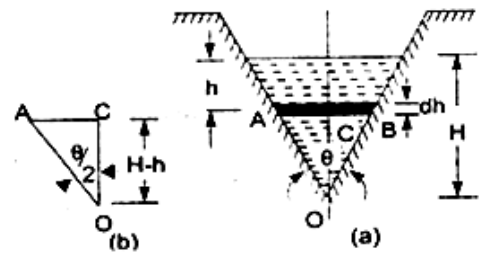

Fig. 2.11

Problem -1

Find the discharge over a triangular notch of angle 60° when the head over the V-notch is 0.3 m. Assume $C_d = 0.6$.

Solution. Given an Angle of V-notch, $\theta = 60^\circ$

Head over notch, $H = 0.3 \text{ m}$

$$C_d = 0.6$$

Discharge, Q over a V-notch is given by equation

$$Q = \frac{8}{15} \times C_d \times \frac{\tan \theta}{2} \times \sqrt{2g} \times H^{5/2}$$

$$\frac{8}{15} \times C_d \times \frac{0.6 \tan 60}{2} \times \sqrt{2 \times 9.81} \times (0.3)^{5/2}$$

$$= 0.8182 \times 0.0493 = 0.040 \text{ m}^3/\text{s. Ans,}$$

Problem -2

Water flows over a rectangular weir 1 m wide at a depth of 150 mm and afterwards passes through a triangular right-angled weir. Taking C_d for the rectangular and triangular weir as 0.62 and 0.59 respectively, find the depth over the triangular weir.

Solution. Given:

For rectangular weir. Length = $L = 1 \text{ m}$

Depth of water, $H = 150 \text{ mm} = 0.15 \text{ m}$

$C_d = 0.62$

For triangular weir.

$\theta = 90^\circ$

$C_d = 0.59$

Let depth over triangular weir = H_1

The discharge over the rectangular weir is given by equation

$$Q = \frac{2}{3} \times C_d \times L \times \sqrt{2g[H]}^{3/2}$$

$$= \frac{2}{3} \times 0.62 \times 1.0 \times \sqrt{2 \times 9.81} \times (0.15)^{3/2}$$

$$= 0.10635 \text{ m}^3/\text{s}$$

The same discharge passes through the triangular right-angled weir. But discharge, Q , is given by the equation

$$Q = \frac{8}{15} \times C_d \times \frac{\tan \theta}{2} \times \sqrt{2g} \times H^{5/2}$$

$$0.10635 = \frac{8}{15} \times 0.59 \times \frac{\tan 90}{2} \times \sqrt{2g} \times H_1^{5/2}$$

$$= \frac{8}{15} \times 0.59 \times 1 \times 4.429 \times H_1^{5/2}$$

$$= 1.3936 H_1^{5/2}$$

$$H_1^{5/2} = \frac{0.10635}{1.3936} = 0.07631$$

$$H_1 = (0.07631)^{0.4} = 0.3572 \text{ m, Ans}$$

Discharge Over A Trapezoidal Notch Or Weir:-

A trapezoidal notch or weir is a combination of a rectangular and triangular notch or weir. Thus the total discharge will be equal to the sum of discharge through a rectangular weir or notch and discharge through a triangular notch or weir.

Let H = Height of water over the notch

L = Length of the crest of the notch

C_{d1} = Co-efficient of discharge for rectangular portion ABCD of Fig.

C_{d2} = Co-efficient of discharge for triangular portion [FAD and BCE]

The-discharge through rectangular portion ABCD is given by

or
$$Q_1 = \frac{2}{3} \times C_{d1} \times L \times \sqrt{2g} \times H^{3/2}$$

The discharge through two triangular notches FDA and BCE is equal to the discharge through a single triangular notch of angle θ and it is given by equation

$$Q_2 = \frac{2}{3} \times C_{d2} \times \frac{\tan \theta}{2} \times \sqrt{2g} \times H^{5/2}$$

Discharge through trapezoidal notch or weir FDCEF = $Q_1 + Q_2$

$$= \frac{2}{3} \times C_{d1} L \sqrt{2g} \times H^{3/2} + \frac{8}{15} C_{d2} \times \frac{\tan \theta}{2} \times \sqrt{2g} \times H^{5/2}$$

Problem -1 Find the discharge through a trapezoidal notch which is 1 m wide at the top and 0.40 m at the bottom and is 30 cm in height. The head of water on the notch is 20 cm. Assume C_d for rectangular portion = 0.62 while for triangular portion = 0.60.

Solution. Given:

Top width $AE = 1$ m
 Base width, $CD = L = 0.4$ m
 Head of water, $H = 0.20$ m
 For rectangular portion, $C_{d1} = 0.62$
 From $\triangle ABC$, we have

$$\begin{aligned} \frac{\tan \theta}{2} &= \frac{AB}{BC} = \frac{AE - CD}{2H} \\ &= \frac{1.0 - 0.4}{2 \times 0.3} = \frac{0.6}{0.6} = 1 \end{aligned}$$

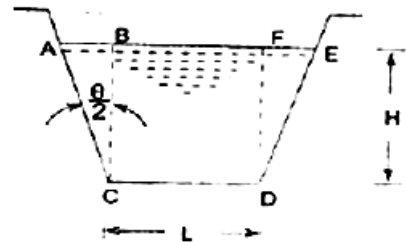

Fig. 2.12

Discharge through trapezoidal notch is given by equation

$$Q = \frac{2}{3} C_{d1} \times L \times \sqrt{2g} \times H^{3/2} + \frac{8}{15} C_{d2} \times \frac{\tan \theta}{2\sqrt{2g}} \times H^{5/2}$$

$$= \frac{2}{3} \times 0.62 \times 0.4 \times \sqrt{2 \times 9.81} \times (0.2)^{3/2} + \frac{8}{15} \times 60 \times 1 \times \sqrt{2 \times 9.81} \times (0.2)^{5/2}$$

$$= 0.06549 + 0.02535 = 0.09084 \text{ m}^3/\text{s} = 90.84 \text{ litres/s. Ans}$$

Discharge Over A Stepped Notch:-

A stepped notch is a combination of rectangular notches. The discharge through 'stepped notch' is equal to the sum of the discharges' through the different rectangular notches.

Consider a stepped notch as shown in Fig.

Let H_1 = Height of water above the crest of notch (1).

L_1 = Length of notch 1,

H_2, L_2 and H_3, L_3 are corresponding values for notches 2 and 3 resp

C_d = Co-efficient of discharge for all notches

Total discharge $Q = Q_1 + Q_2 + Q_3$

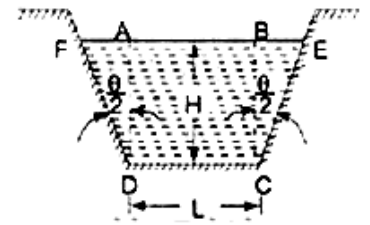

Fig. 2.12

$$Q = \frac{2}{3} \times C_d \times L_1 \times \sqrt{2g} [H_1^{3/2} - H_2^{3/2}] + \frac{2}{3} \times C_d \times L_2 \times \sqrt{2g} [H_2^{3/2} - H_3^{3/2}] + \frac{2}{3} C_d \times L_3 \times \sqrt{2g} \times H_3^{3/2}$$

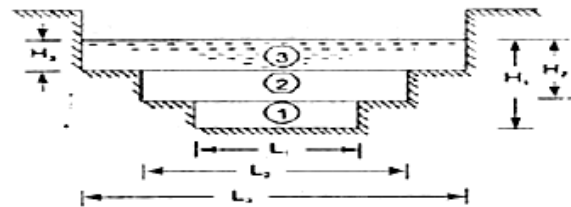

Fig. 2.13

Problem

Fig. 1 shows a stepped notch. Find the discharge through the notch if C_d for all section = 0.62.

Solution. Given:

$L_1 = 40 \text{ cm}, L_2 = 80 \text{ cm},$

$L_3 = 120 \text{ cm}$

$H_1 = 50 + 30 + 15 = 95 \text{ cm},$

$H_2 = 80 \text{ cm}, H_3 = 50 \text{ cm},$

$C_d = 0.62$

Total Discharge, $Q = Q_1 + Q_2 + Q_3$

where

$$Q_1 = \frac{2}{3} \times C_d \times L_1 \times \sqrt{2g} [H_1^{3/2} - H_2^{3/2}]$$

$$= \frac{2}{3} \times 0.62 \times 40 \times \sqrt{2 \times 9.81} \times [95^{3/2} - 80^{3/2}]$$

$$= 154067 \text{ cm}^3/\text{s} = 154.067 \text{ lit/s}$$

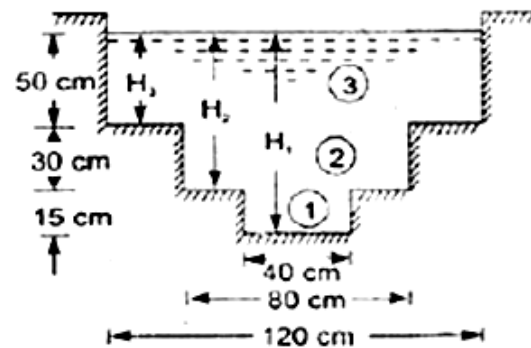

Fig. 2.14

$$Q_2 = \frac{2}{3} \times C_d \times L_2 \times \sqrt{2g} [H_2^{3/2} - H_3^{3/2}]$$

$$= \frac{2}{3} \times 0.62 \times 80 \times \sqrt{2 \times 981} \times [80^{3/2} - 50^{3/2}]$$

$$= 530141 \text{ cm}^3/\text{s}$$

$$= 530.144 \text{ lit/s}$$

$$Q_3 = \frac{2}{3} C_d \times L_3 \times \sqrt{2g} \times H_3^{3/2}$$

$$= \frac{2}{3} \times 0.62 \times 120 \times \sqrt{2 \times 981} \times 50^{3/2}$$

$$= 776771 \text{ cm}^3/\text{s}$$

$$= 776.771 \text{ lit/s}$$

$$\therefore Q = Q_1 + Q_2 + Q_3$$

$$= 154.067 + 530.144 + 776.771$$

$$= 1460.98 \text{ lit/s} \quad \text{Ans.}$$

Velocity Of Approach

Velocity of approach is defined as the velocity with which the water approaches or reaches the weir or notch before it flows over it. Thus if V_a is the velocity of approach, then an additional head h_a equal

to $V_a^2 / 2g$ due to velocity of approach, is acting on the water flowing over the notch. Then initial height of water over the notch becomes $(H + h_a)$ and final height becomes equal to h_a .

Then all the formulae are

changed taking into consideration of velocity of approach.

The velocity of approach, V_a is determined by finding the discharge over the notch or weir neglecting velocity of approach. Then dividing the -discharge-by the cross-sectional area of the channel .on the' upstream side of the weir or notch, the velocity of approach is obtained .

Mathematically,

$$V_a = \frac{Q}{\text{Area of Channel}}$$

This velocity of approach is used to find an additional head ($h_a = V_a^2 / 2g$).Again the discharge is calculated and above process is repeated for more accurate discharge.

Discharge over a rectangular weir, with velocity of approach

$$= \frac{2}{3} \times C_d \times L \times \sqrt{2g} [(H_1 + h_a)^{3/2} - h_a^{3/2}]$$

Problem:-

Water is flowing in a rectangular channel of 1 m wide and 0.75 m deep. Find the discharge over a rectangular weir of crest length 60 cm if the head of water over the crest of weir is 20 cm and water from channel flows over the weir. Take $C_d = 0.62$. Neglect end contractions. Take

velocity of approach into consideration.

Solution. Given:

Area of channel, $A = \text{Width} \times \text{depth} = 1.0 \times 0.75 = 0.75 \text{ m}^2$

Length of weir, $L = 60 \text{ cm} = 0.6 \text{ m}$

Head of water, $H_1 = 20 \text{ cm} = 0.2 \text{ m}$

$C_d = 0.62$

Discharge over a rectangular weir without velocity of approach is given by

$$Q = \frac{2}{3} C_d \times L \times \sqrt{2g} \times H_1^{3/2}$$

$$= \frac{2}{3} \times 0.62 \times 0.6 \times \sqrt{2 \times 9.81} \times (0.2)^{3/2}$$

$$= 0.0982 \text{ m}^3/\text{s}$$

$$\text{velocity of approach } V_a = \frac{Q}{A} = \frac{0.0982}{0.75} = 0.1309 \frac{\text{m}}{\text{s}}$$

Additional head $h_a = V_a^2 / 2g$

$$= (0.1309)^2 / 2 \times 9.81 = 0.0008733 \text{ m}$$

Then discharge with velocity of approach is given by equation

$$Q = \frac{2}{3} \times C_d \times L \times \sqrt{2g} [(H_1 + h_a)^{3/2} - h_a^{3/2}]$$

$$= \frac{2}{3} \times 0.62 \times 0.6 \times \sqrt{2 \times 9.81} [(0.2 + 0.00087)^{3/2} - (0.00087)^{3/2}]$$

$$= 1.098 [0.09002 - 0.00002566]$$

$$= 1.098 \times 0.09017$$

$$= 0.09881 \text{ m}^3/\text{s. Ans}$$

Types of Weirs :-

Though there are numerous types of weirs, yet the following are important from the subject point of view :

1. Narrow-crested weirs,
2. Broad-crested weirs,

3. Sharp-crested weirs,
4. Ogee weirs, and
5. Submerged or drowned weirs.

Discharge over a Narrow-crested Weir :-

The weirs are generally classified according to the width of their crests into two types. i.e. narrow-crested weirs and broad crested weirs.

Let b = Width of the crest of the weir, and
 H = Height of water above the weir crest.

If $2b$ is less than H , the weir is called a narrow-crested weir. But if $2b$ is more than H , it is called a broad-crested weir.

A narrow-crested weir is hydraulically similar to an ordinary weir or to a rectangular weir. Thus, the same formula for discharge over a narrow-crested weir holds good, which we derived from an ordinary weir.

$$Q = \frac{2}{3} \times C_d \cdot L \sqrt{2g} \times H^{3/2}$$

Where, Q = Discharge over the weir,

C_d = Coefficient of discharge,

L = Length of the weir, and

H = Height of water level above the crest of the weir.

Example A narrow-crested weir of 10 metres long is discharging water under a constant head of 400 mm. Find discharge over the weir in litres. Assume coefficient of discharge as 0.623.

Solution. Given: $L = 10$ m; $H = 400$ mm = 0.4 m and $C_d = 0.623$.
 We know that the discharge over the weir,

$$\begin{aligned} Q &= \frac{2}{3} \times C_d \cdot L \sqrt{2g} \times H^{3/2} \\ &= \frac{2}{3} \times 0.623 \times 10 \sqrt{(2 \times 9.81)} \times (0.4)^{3/2} \\ &= 46.55 \text{ m}^3/\text{s} = 4655 \text{ lit/s} \end{aligned}$$

Discharge over a Broad-crested Weir :-

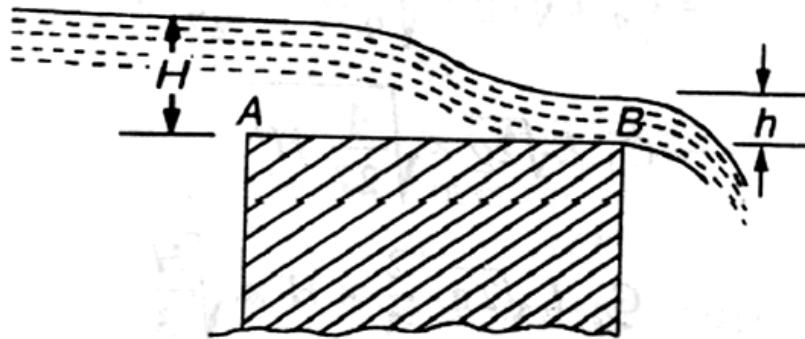

Fig. 2.15

Broad-crested weir

Consider a broad-crested weir as shown in Fig. Let A and B be the upstream and downstream ends of the weir.

- Let H = Head of water on the upstream side of the weir (i.e., at A),
- h = Head of water on the downstream side of the weir (i.e., at B),
- v = Velocity of the water on the downstream side of the weir (i.e., at B),
- C_d = Coefficient of discharge, and
- L = Length of the weir.

$$Q = 1.71 C_d \cdot L \times H^{3/2}$$

Example A broad-crested weir 20 m long is discharging water from a reservoir in to channel. What will be the discharge over the weir, if the head of water on the upstream and downstream sides is 1m and 0.5 m respectively? Take coefficient of discharge for the flow as 0.6 .

Solution. Given: $L = 20$ m; $H = 1$ m; $h = 0.5$ m and $C_d = 0.6$.

We know that the discharge over the weir,

$$\begin{aligned}
 Q &= C_d \times L \cdot h \sqrt{2g(H - h)} \\
 &= 0.6 \times 2.0 \times 0.5 \times \sqrt{2 \times 9.81(1 - 0.5)} \text{ m}^3/\text{s} \\
 &= 6 \times 3.13 = 18.8 \text{ m}^3/\text{s} \quad \text{Ans.}
 \end{aligned}$$

Discharge over a Sharp-crested Weir :-

It is a special type of weir, having a sharp-crest as shown in Fig. The water flowing over the crest comes in contact with the crest-line and then springs up from the crest and falls as a trajectory as shown in Fig.

In a sharp-crested weir, the thickness of the weir is kept less than half of the height of water on the weir. i.e.,

$$b < (H/2)$$

where, b = Thickness of the weir,

and H = Height of water, above the crest of the weir.

The discharge equation, for a sharp crested weir, remains the same as that of a rectangular weir. i.e.,

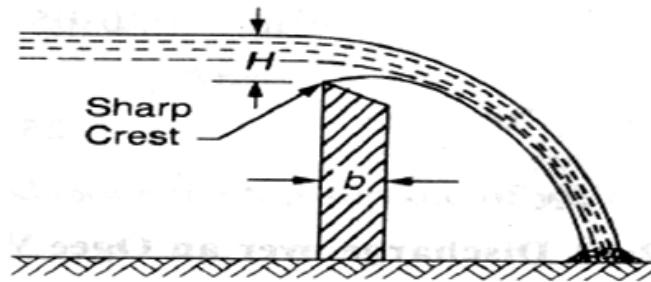

Fig. 2.16

Sharp-crested weir :-

$$Q = \frac{2}{3} \times C_d \cdot L \sqrt{2g} \times H^{3/2}$$

Where, C_d = Coefficient of discharge, and
 L = Length of sharp-crested weir

Example In a laboratory experiment, water flows over a sharp-crested weir 200 mm long under a constant head of 75mm. Find the discharge over the weir in litres/s, if $C_d = 0.6$.

Solution. Given: $L = 200 \text{ mm} = 0.2 \text{ m}$; $H = 75 \text{ mm} = 0.075 \text{ m}$ and $C_d = 0.6$.

We know that the discharge over the weir,

$$\begin{aligned} Q &= \frac{2}{3} \times C_d \cdot L \sqrt{2g} \times H^{3/2} \\ &= \frac{2}{3} \times 0.6 \times 0.2 \times \sqrt{2 \times 9.81} \times (0.075)^{3/2} \\ &= 0.0073 \text{ m}^3/\text{s} = 7.3 \text{ litres/s. Ans.} \end{aligned}$$

Discharge over an Ogee Weir :-

It is a special type of weir, generally, used as a spillway of a dam as shown in Fig.

, The crest of an ogee weir slightly rises up from the point A, (i.e., crest of the sharp-crested weir) and after reaching the maximum rise of $0.115 H$ (where H is the height of a water above the point A) falls in a parabolic form as shown in Fig.

The discharge equation for an ogee weir remains the same as that of a rectangular weir. i.e.,

$$Q = \frac{2}{3} \times C_d \cdot L \sqrt{2g} \times H^{3/2}$$

Where C_d = Co-efficient of discharge and
 L = Length of an ogee weir

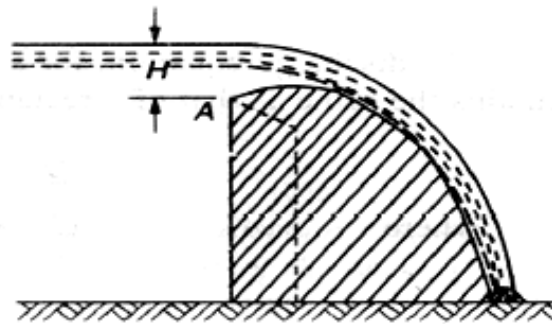

Fig. 2.17

Example

An ogee weir 4 metres long has 500 mm head of water. Find the discharge over the weir, if $C_d = 0.62$.

Solution. Given: $L = 4$ m; $H = 500$ mm = 0.5 m and $C_d = 0.62$.

We know that the discharge over the weir,

$$Q = \frac{2}{3} \times C_d \cdot L \sqrt{2g} \times H^{3/2}$$

$$= \frac{2}{3} \times 0.62 \times 4 \sqrt{2 \times 9.81} \times (0.5)^{3/2} \text{ m}^3/\text{s}$$

$$= 7.323 \times 0.354 = 2.59 \text{ m}^3/\text{s} = 2590 \text{ litres/s} \quad \text{Ans}$$

Discharge over a Submerged or Drowned Weir :-

When the water level on the downstream side of a weir is above the top surface of weir, it is known as a submerged or drowned weir as shown in Fig

The total discharge, over such a weir, is found out by splitting up the height of water, above the sill of the weir, into two portions as discussed below:

Let H_1 = Height of water on the upstream side of the weir, and
 H_2 = height of water on the downstream side
of the weir.

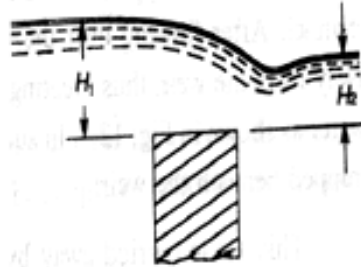

Fig. 2.18

The discharge over the upper portion may be considered as a free discharge under a head of water equal to $(H_1 - H_2)$. And the discharge over the lower portion may be considered as a submerged discharge under a head of H_2 . Thus discharge over the free portion (i.e., upper portion),

$$Q_1 = \frac{2}{3} \times C_d \cdot L \sqrt{2g} \times (H_1 - H_2)^{3/2}$$

Submerged weir :-

and the discharge over the submerged (i.e., lower portion),

$$Q_2 = C_d \cdot L \cdot H_2 \cdot \sqrt{2g(H_1 - H_2)}$$

$$\therefore \text{Total discharge, } Q = Q_1 + Q_2$$

Example A submerged sharp crested weir 0.8 metre high stands clear across a channel having vertical sides and a width of 3 meters. The depth of water in the channel of approach is 1.2 meter. And 10 meters downstream from the weir, the depth of water is 1 meter. Determine the discharge over the weir in liters per second. Take C_d as 0.6.

Solution. Given: $L = 3$ m and $C_d = 0.6$.

From the geometry of the weir, we find that the depth of water on the upstream side,

$$H_1 = 1.25 - 0.8 = 0.45 \text{ m and depth of water on the downstream side,}$$

$$H_2 = 1 - 0.8 = 0.2 \text{ m}$$

We know that the discharge over the free portion of the weir

$$Q_1 = \frac{2}{3} \times C_d \cdot L \sqrt{2g} \times (H_1 - H_2)^{3/2}$$

$$= \frac{2}{3} \times 0.6 \times 3 \times (\sqrt{2 \times 9.81})(0.45 - 0.20)^{3/2}$$

$$= 5.315 \times 0.125 = 0.664 \text{ m}^3/\text{s} = 664 \text{ liters/s} \quad \dots \text{ (i)}$$

and discharge over the submerged portion of the weir,

$$Q_2 = C_d \cdot L \cdot H_2 \cdot \sqrt{2g(H_1 - H_2)}$$

$$= 0.6 \times 3 \times 0.2 \sqrt{2 \times 9.81(0.45 - 0.2)} \text{ m}^3/\text{s}$$

$$= 0.36 \times 2.215 = 0.797 \text{ m}^3/\text{s} = 797 \text{ liters/s} \quad \dots \text{ (ii)}$$

\therefore Total discharge: $Q = Q_1 + Q_2 = 664 + 797 = 1461 \text{ liters/s}$ **Ans.**

2.3 Flow over Weirs:-

An open channel is a passage through which the water flows under the force of gravity - atmospheric pressure. Or in other words, when the free surface of the flowing water is in contact, with the atmosphere as in the case of a canal, a sewer or an aqueduct, the flow is said to be through an open channel. A channel may be covered or open at the top. As a matter of fact, the flow of water in an open channel, is not due to any pressure as in the case of pipe flow. But it is due to the slope the bed of the channel. Thus during the construction of a channel, a uniform slope in its bed is provided to maintain the flow of water.

Chezy's Formula for Discharge through an Open Channel :-

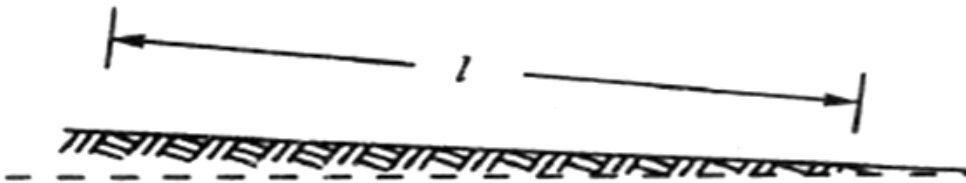

Fig. 2.19

Sloping bed of a channel :-

Consider an open channel of uniform cross-section and bed slope as shown in Fig.

Let

l = Length of the channel,

A = Area of flow,

v = Velocity of water,

p = Wetted perimeter of the cross-section, m =

f = Frictional resistance per unit area at unit velocity, and

i = Uniform slope in the bed.

$m = \frac{A}{P}$ (known as hydraulic mean depth or hydraulic radius)

∴ Discharge $Q = A \times v = AC\sqrt{mi}$

Example.

A rectangular channel is 1.5 metres deep and 6 metres wide. Find the discharge through channel, when it runs full. Take slope of the bed as 1 in 900 and Chezy's constant as 50.

Solution. Given: $d = 1.5$ m; $b = 6$ m; $i = 1/900$ and $C = 50$.

We know that the area of the channel,

$$A = b.d = 6 \times 1.5 = 9 \text{ m}^2$$

and wetted perimeter, $D = b + 2d = 6 + (2 \times 1.5) = 9 \text{ m}$

∴ Hydraulic mean depth, $m = \frac{A}{P} = 1 \text{ m}$

and the discharge through the channel,

$$Q = AC\sqrt{mi} = 9 \times 50 \sqrt{1 \times 1/900} = 15 \text{ m}^3/\text{s} \quad \text{Ans.}$$

Manning Formula for Discharge :-

Manning, after carrying out a series of experiments, deduced the following relation for the value of C in Chezy's formula for discharge:

$$C = \frac{1}{N} \times m^{1/6}$$

where N is the Kutter's constant

Now we see that the velocity,

$$v = C\sqrt{mi} = M \times m^{2/3} \times i^{1/2}$$

where

$M = 1/N$ and is known as Manning's constant.

Now the discharge,

$$Q = \text{Area} \times \text{Velocity} = A \times 1/N \times m^{2/3} \times i^{1/2}$$

$$= A \times M \times m^{2/3} \times i^{1/2}$$

Example

An earthen channel with a 3 m wide base and side slopes 1 : 1 carries water with a depth of 1 m. The bed slope is 1 in 1600. Estimate the discharge. Take value of N in Manning's formula as 0.04.

Solution.

Given: $b = 3$ m; Side slopes = 1 : 1; $d = 1$ m; $i = 1/1600$ and $N = 0.04$.

We know that the area of flow,

$$A = \frac{1}{2} \times (3 + 5) \times 1 = 4 \text{ m}^2$$

and wetted perimeter,

$$P = 3 + 2 \times \sqrt{(1)^2 + (1)^2} = 5.83 \text{ m}$$

$$\therefore \text{hydraulic mean depth } m = A/P = 4/5.83 = 0.686 \text{ m}$$

We know that the discharge through the channel

$$Q = \text{Area} \times \text{Velocity} = A \times \frac{1}{N} \times m^{2/3} \times i^{1/2}$$

$$= 4 \times \frac{1}{0.04} \times 0.686^{2/3} \times (1/1600)^{1/2}$$

$$= 1.945 \text{ m}^3/\text{s} \text{ Ans}$$

Channels of Most Economical Cross-sections :-

A channel, which gives maximum discharge for a given cross-sectional area and bed slope is called a channel of most economical cross-section. Or in other words, it is a channel which involves least excavation for a designed amount of discharge. A channel of most economical cross-section is, sometimes: also defined as a channel which has a minimum wetted perimeter; so that there is a minimum resistance to flow and thus resulting in a maximum discharge. From the above definitions,

it is obvious that while deriving the condition for a channel of most economical cross-section, the cross-sectional area is assumed to be constant. The relation between depth and breadth of the section is found out to give the maximum discharge.

The conditions for maximum discharge for the following sections will be dealt with in the succeeding pages :

1. Rectangular section,
2. Trapezoidal section, and
3. Circular section.

Condition for Maximum Discharge through a Channel of Rectangular Section :-

A rectangular section is, usually, not provided in channels except in rocky soils where the faces of rocks can stand vertically. Though a rectangular section is not of much practical importance, yet we shall discuss it for its theoretical importance only.

Consider a channel of rectangular section as shown in Fig.

Let

b = Breadth of the channel, and

d = Depth of the channel.

$$A = b \times d$$

$$\text{Discharge } Q = A \times v = AC \sqrt{mi}$$

$$m = A/P$$

$$= d/2$$

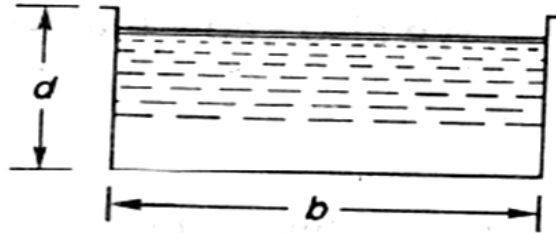

Fig. 2.20

Hence, for maximum discharge or maximum velocity, these two conditions (i.e., $b = 2d$ and $m = d/2$) should be used for solving the problems of channels of rectangular cross-sections.

Example

A rectangular channel has a cross-section of 8 square metres. Find its size and discharge through the most economical section, if bed slope is 1 in 1000. Take $C = 55$.

Solution. Given: $A = 8 \text{ m}^2$

$$i = 1/1000 = 0.001 \text{ and } C = 55.$$

Size of the channel

Let

b = Breadth of the channel, and

d = Depth of the channel.

We know that for the most economical rectangular section,

$$b = 2d$$

$$\therefore \text{Area (A)} = 8 = b \times d = 2d \times d = 2d^2$$

$$= b = 2 \text{ m}$$

$$\text{And } b = 2d = 2 \times 2 = 4 \text{ m}$$

Discharge through the channel

We also know that for the most economical rectangular section, hydraulic mean depth,

$$m = d/2 = 2/2 = 1 \text{ m}$$

and the discharge through the channel,

$$Q = AC \sqrt{mi} = 8 \times 55 \sqrt{1 \times 0.001} \text{ m}^3/\text{s}$$

$$= 440 \times 0.0316 = 13.9 \text{ m}^3/\text{s}, \text{ Ans.}$$

Condition for Maximum Discharge through a Channel of Trapezoidal Section :-

A trapezoidal section is always provided in the earthen channels. The side slopes, in a channel of trapezoidal cross-section are provided, so that the soil can stand safely. Generally, the side slope in a particular soil is decided after conducting experiments on that soil. In a soft soil, flatter side slopes

should be provided whereas in a harder one, steeper side slopes may be provided.

consider a channel of trapezoidal cross-section ABCD as shown in Fig.

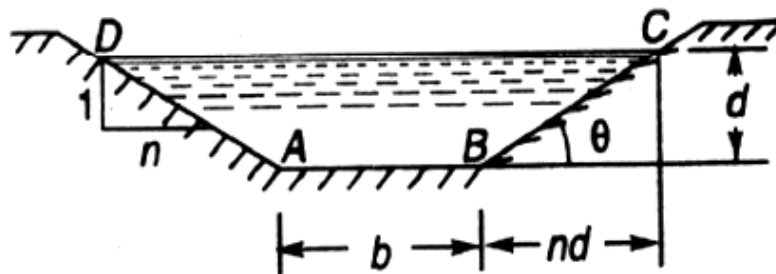

Fig. 2.21

Let

b = Breadth of the channel at the bottom,

d = Depth of the channel and

$\frac{1}{n}$ = side slope (i.e., 1 vertical to n horizontal)

Hence, for maximum discharge or maximum velocity these two (i.e., $b + 2nd/2 = d\sqrt{n^2 + 1}$ and $m = d/2$) should be used for solving problems on channels of trapezoidal cross-sections.

Example .

A most economical trapezoidal channel has an area of flow 3.5 m^2 discharge in the channel, when running 1 metre deep. Take $C = 60$ and bed slope 1 in 800.

Solution. Given: $A = 3.5 \text{ m}^2$; $d = 1 \text{ m}$; $C = 60$ and $i = 1/800$.

We know that for the most economical trapezoidal channel the hydraulic mean depth

$$m = d/2 = 0.5 \text{ m}$$

and discharge in the channel,

$$Q = A.C.\sqrt{mi} = 5.25 \text{ m}^3/\text{s} \text{ Ans.}$$

Example .

A trapezoidal channel having side slopes of 1 : 1 and bed slope of 1 in 1200 is required to carry a discharge of 1800 m³/min. Find the dimensions of the channel for cross-section. Take Chezy's constant as 50.

Solution.

Given side slope (n)=1

(i.e. 1 vertical to n horizontal),

i= 1/1200 ,Q= 180m³/min = 3m³/sec

and C = 50

Let b=breadth of the channel of its bottom and d= depth of the water flow.

We know that for minimum cross section the channel should be most economical and for economical trapezoidal section half of the top width is equal to the slopping side. i.e.

$$b + 2nd/2 = d \sqrt{n^2 + 1}$$

or b = 0.828d

$$\therefore \text{Area } A = d \times (b + nd) = 1.828d^2$$

We know that in the case of a most economical trapizodial section the hydraulic mean depth m=d/2

And discharge through the channel (Q)= A.C. \sqrt{mi} =1.866d^{5/2}

$$\therefore d^{5/2} = 3/1.866 = 1.608$$

Or d = 1.21 m

$$\therefore b = 0.828 d = 0.828 \times 1.21 = 1 \text{ m ANS}$$

Condition for Maximum Velocity through a Channel of Circular Section :-

Consider a channel 'of circular section, discharging water under the atmospheric pressure shown in Fig.

Let r = Radius of the channel,

h = Depth of water in the channel, and

2θ = Total angle (in radians) subtended at the centre by the water

From the geometry of the figure, we find that the wetted perimeter of the channels,

$$P = 2r \theta \quad \dots(i)$$

and area of the section, through which the water is flowing,

$$A = r^2 \theta - \frac{r^2 \sin 2\theta}{2} = r^2 \left(\theta - \frac{\sin 2\theta}{2} \right) \quad \dots(ii)$$

We know that the velocity of flow in an open channel,

$$Q = A.C.\sqrt{mi}$$

We know that the velocity of flow in an open channel, $v = C\sqrt{mi}$

Problem: Find the maximum velocity of water in a circular channel of 500 mm radius, if the bed slope is 1 in 400. Take Manning's constant as 50.

Solution:-

Given $d = 500\text{mm} = 0.5\text{m}$ or $r = 0.5/2 = 0.25\text{m}$, $i = 1/400$ and $M = 50$

Let 2θ = total angle (in radian) subtended by the water surface at the centre of the channel.

Now we know that for maximum velocity, the angle subtended by the water surface at the centre of the channel.

$$2\theta = 257^{\circ}30' \text{ or } \theta = 128.75^{\circ} = 128.75 \times \frac{\pi}{180} = 2.247\text{rad}$$

$$\therefore \text{Area of flow, } A = r^2 \left(\theta - \frac{\sin 2\theta}{2} \right) = 171\text{m}^2$$

$$\text{And perimeter } P = 2r\theta = 1.124\text{m}$$

$$\therefore \text{hydraulic mean depth } m = A/P = 0.171/1.124 = 0.152\text{m}$$

$$\text{And velocity of water } v = M X m^{2/3} X i^{1/2} = 0.71\text{m/s} \quad \text{ANS}$$

PUMPS

3.1 Centrifugal Pumps:-

The hydraulic machines which convert the mechanical energy to hydraulic energy are called pumps. The hydraulic energy is in the form of pressure energy. If the mechanical energy is converted, into pressure energy by means of centrifugal force acting on the fluid, the hydraulic machine is called centrifugal pump.

The centrifugal pump works on the principle of forced vortex flow which means that when a certain mass of liquid is rotated by an external torque, the rise in pressure head of the rotating liquid takes place. The rise in pressure head at any point of the rotating liquid is proportional to the square of tangential velocity of the liquid at that point (i.e. , rise in pressure

head = $\frac{v^2}{2g}$ or $\frac{\omega^2 r^2}{2g}$) . Thus at the outlet of the impeller, where radius is more , the rise in pressure head will be more & the liquid will be more & the liquid will be discharged at the outlet with a high pressure head. Due to this high pressure head, the liquid can be lifted to a high level.

Main Parts Of A Centrifugal Pump:-

The followings are the main parts of a centrifugal pump:

1. Impeller
2. Casing
3. Suction pipe with a foot valve & a strainer
4. Delivery Pipe

All the main parts of the centrifugal pump are shown in Fig 19.1

1. **Impeller:** The rotating part of a centrifugal pump is called 'impeller'. It consists of a series of backward curved vanes. The impeller is mounted on a shaft which is connected to the shaft of an electric motor.
2. **Casing:** The casing of a centrifugal pump is similar to the casing of a reaction turbine. It is an air-tight passage surrounding the impeller & is designed in such a way that the kinetic energy of the water discharged at the outlet of the impeller is converted into pressure energy

before the water leaves the casing & enters the delivery pipe. The following three types of the casings are commonly adopted:

- a. Volute **casing** as shown in Fig.19.1
- b. Vortex casing as shown in Fig.19.2(a)
- c. Casing with guide blades as shown in Fig.19.2(b)

a) **Volute casing** as shown in Fig.3.1 the Volute casing, which is surrounding the impeller. It is of spiral type in which area of flow increases gradually. The increase in area of flow decrease velocity of flow. Decrease in velocity increases the pressure of water flowing through casing. it has been observed that in case of volute casing, the efficiency of pump increases.

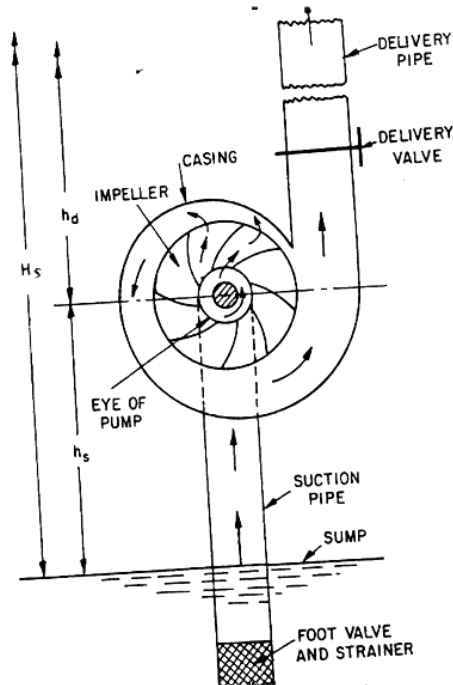

Main parts of a centrifugal pump

Fig. 3.1

b) **Vortex casing.** if a circular chamber is introduced between the casing and impeller as shown in fig.3.1, the casing is known as vortex casing. by introducing the circular chamber, loss of energy due to formation of eddies is reduced to a considerable extent. thus efficiency of pump is more than the efficiency when only volute casing is provided.

c) **Casing with guide blades.** This casing is shown in fig.3.1 in which the impeller is surrounded by a series of guide blades mounted on a ring which is known as diffuser. the guide vanes are designed in which a way that the water from the impeller enters the guide vanes without stock. Also the area of guide vanes increases, thus reducing the velocity of flow through guide vanes and consequently increasing the pressure of water. the water from guide vanes then passes through the surrounding casing which is in most of cases concentric with the impeller as shown in fig.3.1.

3. suction pipe with foot-valve and a strainer: A pipe whose one end is connected to the inlet of pump and other end dips into water in a sump is known as suction pipe. A foot valve which is a non-return valve or one –way type valve is fitted at lower end of suction pipe. Foot valve opens only in upward direction. A strainer is also fitted at lower end of suction pipe.

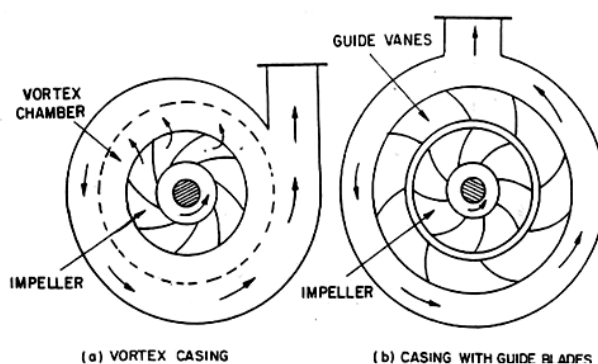

fferent type of casing

Fig: 3.2

4. Delivery pipe: a pipe whose one end is connected to outlet of pump and other end delivers water at a required height is known as delivery pipe.

Efficiencies of a centrifugal pump: Efficiencies of a centrifugal pump: In case of a centrifugal pump , the power is transmitted from the shaft of the electric motor to the shaft of the pump & then to the impeller. From the impeller, the power is given to the water. Thus power is decreasing from the shaft of the pump to the impeller & then to the water. The following are the important efficiencies of a centrifugal pump:

- a. Manometric efficiencies η_{man}
- b. Mechanical efficiencies η_m

c. Overall efficiencies η_o

a) **Manometric Efficiencies η_{man}** : The ratio of the manometric head to the head imparted by the impeller to the water is known as manometric efficiency. It is written as

η_{max} = Manometric head/Head imparted by impeller to water

$$= \frac{H_m}{\frac{V_{w2}u_2}{g}} = \frac{gH_m}{V_{w2}u_2} \dots\dots\dots$$

The impeller at the impeller of the pump is more than the power given to the water at outlet of the pump. The ratio of the power given to water at outlet of the pump to the power available at the impeller, is known as manometric efficiency.

The power given to water at outlet of the pump = $\frac{WH_m}{1000} kW$

The power at the impeller = $\frac{\text{Work done by impeller per second } kW}{1000}$

$$\begin{aligned} & \frac{W}{g} \times \frac{V_{w2}u_2}{1000} kW \\ = & \frac{WH_m}{1000} \\ \eta_{max} = & \frac{\frac{WH_m}{1000}}{\frac{W}{g} \times \frac{V_{w2}u_2}{1000}} = \frac{gH_m}{V_{w2} \times u_2} \end{aligned}$$

b) **Mechanical efficiencies:-**

The power at the shaft of the centrifugal pump is more than the power available at the impeller of the pump . The ratio of the power available at the impeller to the power at the shaft of the centrifugal pump is known as mechanical efficiency. It is written as

$$\eta_m = \text{Power at the impeller} / \text{Power at the shaft}$$

The power at the impeller in kW = Work done by impeller per second / 10000

$$= \frac{W}{g} \times \frac{V_{w2} u_2}{1000}$$

$$\eta_m = \frac{\frac{W}{g} \left(\frac{V_{w2} u_2}{1000} \right)}{S.P.} \dots\dots\dots$$

Where S.P.= Shaft Power

c) **Overall efficiencies** η_o

It is defined as the ratio of power output of the pump to the power input to the pump .
The power output of the pump in kW

$$= \frac{\text{Weight of water lifted} \cdot H_m}{1000} = \frac{WH_m}{1000}$$

Power input to the pump =Power supplied by the electric motor

= S.P. of the pump

$$= \eta_o = \frac{\left(\frac{WH_m}{1000} \right)}{S.P.} \dots\dots\dots$$

$$= \eta_{man} \times \eta_m \dots\dots\dots$$

Problem 3.1: The internal & external diameters of the impeller of a centrifugal pump are 200mm & 400mm respectively. The pump is running at 1200 r.p.m. The vane angles of the impeller at inlet & outlet are 20° & 30° respectively. The water enters the impeller radially & velocity of flow is constant. Determine the velocity of flow per metre sec.

Solution: Internal Dia. Of impeller, $=D_1=200\text{mm}=0.20\text{m}$

External Dia. Of impeller , $=D_2=400\text{mm}=0.40\text{m}$

Speed $N=1200\text{r.p.m}$

Vane angle at inlet , $\theta = 20^\circ$

Vane angle at outlet, $\phi = 30^\circ$

Water enters radially means, $\alpha = 90^\circ$ and $V_{w1} = 0$

Velocity of flow , $=V_{f1} = V_{f2}$

Tangential velocity of impeller at inlet & outlet are,

$$u_1 = \frac{\pi D_1 N}{60} = \frac{\pi \times .20 \times 1200}{60} = 12.56 m/s$$
$$u_2 = \frac{\pi D_2 N}{60} = \frac{\pi \times .40 \times 1200}{60} = 25.13 m/s$$

From inlet velocity triangle,

$$\tan \phi = \frac{V_{f1}}{u_1} = \frac{V_{f2}}{12.56}$$
$$V_{f1} = 12.56 \tan \theta = 12.56 \times \tan 20 = 4.57 m/s$$
$$V_{f2} = V_{f1} = 4.57 m/s$$

Problem 3.2: A centrifugal pump delivers water against a net head of 14.5 metres & a design speed of 1000r.p.m. The values are back to an angle of 30° with the periphery. The impeller diameter is 300mm & outlet width 50mm. Determine the discharge of the pump if manometric efficiency is 95%.

Solution: Net head, $H_m = 14.5m$

Speed, $N = 1000r.p.m$

Vane angle at outlet, $\phi = 30^\circ$

Impeller diameter means the diameter of the impeller at outlet

Diameter, $D_2 = 300mm = 0.30m$

Outlet width, $B_2 = 50mm = 0.05m$

Manometric efficiency, $\eta_{man} = 95\% = 0.95$

Tangential velocity of impeller at outlet, $u_2 = \frac{\pi D_2 N}{60} = \frac{\pi \times .30 \times 1000}{60} = 15.70 m/s$

Now using equation

$$\eta_{\max} = \frac{gH_m}{V_{w2}u_2}$$

$$0.95 = \frac{9.81 \times 14.5}{V_{w2} \times 15.70}$$

$$V_{w2} = \frac{0.95 \times 14.5}{0.95 \times 15.70} = 9.54 \text{ m/s}$$

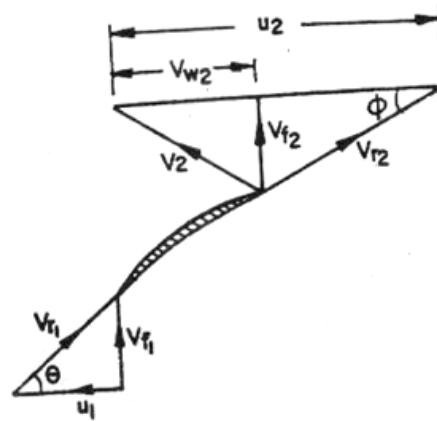

Fig. 3.3

Refer to fig(3.3). From outlet velocity triangle, we have

$$\tan \phi = \frac{V_{f2}}{(u_2 - V_{w2})}$$

$$\tan 30^\circ = \frac{V_{f2}}{(15.70 - 9.54)} = \frac{V_{f2}}{6.16}$$

$$V_{f2} = 6.16 \times \tan 30^\circ = 3.556 \text{ m/s}$$

$$\text{Discharge } Q = \pi \times D_2 \times B_2 \times V_{f2}$$

$$= \pi \times 0.30 \times 0.05 \times 3.556 \text{ m}^3 / \text{s} = 0.1675 \text{ m}^3 / \text{s}$$

3.2 Reciprocating Pump:-

Introduction:-

We have defined the pumps as the hydraulic machines which convert the mechanical energy to hydraulic energy which is mainly in the form of pressure energy. If the mechanical energy is converted into hydraulic energy (or pressure energy) by sucking the liquid into a cylinder in which a piston is reciprocating (moving backwards and forwards), which exerts the thrust on the liquid & increases its hydraulic energy (pressure energy), the pump is known as reciprocating pump.

Main parts of a reciprocating pump:-

The following are the main parts of a reciprocating pump as shown in fig (3.4)

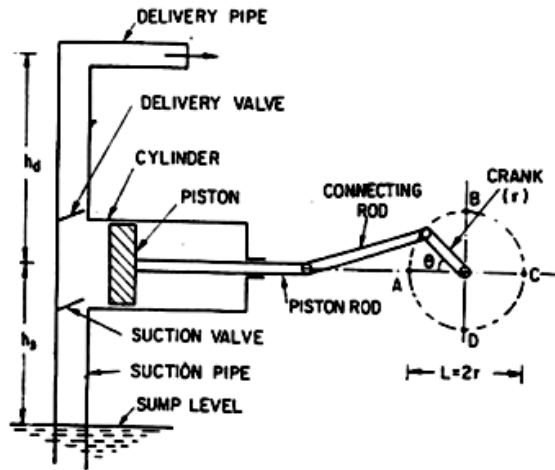

Main parts of a reciprocating pump.

1. A cylinder with a piston, piston rod, connecting rod and a crank,
2. Suction pipe,
3. Delivery pipe,
4. Suction valve, and
5. Delivery valve.

Fig. 3.4

Discharge through a Reciprocating Pump: Consider a single acting reciprocating pump as shown in fig ().

Let D = dia. Of the cylinder

A = C/s area of the piston or cylinder

$$= \frac{\pi}{4} D^2$$

r = Radius of crank

N = r.p.m of the crank

L = Length of the stroke = $2 \cdot r$

h_s = height of the axis of the cylinder from water surface in sump

h_d = Height of the delivery outlet above the cylinder axis (also called delivery head)

Volume of water delivered in one revolution or discharge of water in one revolution

$$= \text{Area} * \text{Length of stroke} = A * L$$

Number of revolution per second, = $\frac{N}{60}$

Discharge of the pump per second , Q= Discharge in one direction × No. of revolution per second

$$= A \times L \times \frac{N}{60} = \frac{ALN}{60} \dots\dots\dots$$

Wt. of water delivered per second, $W = \rho g Q = \frac{\rho g ALN}{60} \dots\dots\dots$

Work done by Reciprocating Pump : Work done by the reciprocating pump per sec. is given by the reaction as

Work done per second = Weight of water lifted per second × Total height through which water is lifted

$$= W \times (h_s + h_d)$$

Where $(h_s + h_d)$ = Total height through which water is lifted

From equation () Weight, W is given by $W = \frac{\rho g ALN}{60}$

Substituting the value of W in equation () we get

Work done per second =

$$\frac{\rho g ALN}{60} (h_s + h_d) \dots\dots\dots$$

Power required to drive the pump, in kW $P = \frac{\text{Work done per second}}{1000} =$

$$\frac{\rho \times g \times ALN(h_s + h_d)}{60 \times 1000}$$

$$= \frac{\rho g ALN(h_s + h_d)}{60,000} \text{ kW} \dots\dots\dots$$

Classification of reciprocating pumps:

The reciprocating pumps may be classified as:

1. According to the water being in contact with one side or both sides of the piston, and
2. According to the number of cylinders provided

If the water is in contact with one side of the piston, the pump is known as single-acting. On the other hand,

If the water is in contact with both sides of the piston, the pump is called double –acting. Hence, classification according to the contact of water is:

- I. Single-acting pump
- II. Double –acting pump

According to the number of cylinder provided, the pumps are classified as:

- I. Single cylinder pump
- II. Double cylinder pump
- III. Triple cylinder pump